

**IWAKI MAGNET
GEAR PUMP**

MDG – M2

**I N S T R U C T I O N
M A N U A L**

- Inspection and Unpacking (1)
- Principle of Operation (2)
- Pump Identification Codes (3)
- Names of Parts and Structure (4)
- Precautionary Measures (5)
- Installation, Piping and Wiring (6)
- Operation (7)
- Maintenance and Inspection (8)
- Causes of Trouble and Troubleshooting (9)
- Disassembling and Reassembling (10)
- Performance and Sizes (11)

Safety Instruction

Warning

- **Turn off the power supply.**
Working without disconnecting the power supply may cause an electrical shock. Before engaging upon any working procedures involving the pump, make sure to turn the power supply switch off and to stop the pump and other related devices.
- **Terminate operation!**
When you detect or become aware of a dangerous sign or abnormal condition during operation, terminate the operation immediately and start it from the beginning again.
- **For specified application only.**
The use of a pump in an application other than those clearly specified may result in injury or damage to the pump. Use the pump strictly in accordance with the pump specifications and application range.
- **No remodeling!**
Never remodel a pump. Otherwise, a serious accident may result. Iwaki will not be responsible for any accident or damage of any kind which is caused by the user remodeling the pump without first obtaining permission or instructions from Iwaki.
- **Wear protectors.**
If you touch or come in contact with any type of hazardous chemical liquid, including but not limited to chemicals, you may experience a serious injury. Wear protective gear (protective mask, gloves, etc.) during the pump operation.



Caution

- **Qualified operators only!**
The pump operator and pump operation supervisor must not allow any operators who have little or no knowledge of the pump to run or operate the pump. Pump operators must have a sound knowledge of the pump and its operation.
- **Specified power only.**
Do not operate the pump on voltage which is not specified on the nameplate. Failure to do so may result in damage or fire. Only the specified power level is to be applied.
- **Do not wet or dampen!**
If the motor or wiring cable becomes wet or dampened with the operating liquid by mistake, this may result in a fire or cause an electrical shock. Install the motor and wiring cable in positions which are not likely to become wet or dampened with any liquid.
- **Ventilate!**
Poisoning may result during an operation which involves toxic or odorous liquid. Ventilate the operating site sufficiently.
- **Spill-out accident!**
Protective measures should be taken against any accidental spill-out or leakage of the operating liquid as a result of unexpected damage on the pump or the related piping.



Caution

- **Damaged pump**
Never operate a damaged pump. A damaged pump may cause leakage or electrical shock.
- **Operating site must be free of water and humidity**
The pump is not designed to be water-proof or dust-proof. The use of the pump in places where water splashes or humidity is high may result in an electrical shock or short circuit.
- **Do not damage or change power cable!**
Do not scratch, damage, process, or pull the power cable forcibly. An extra load onto the cable, such as heating the cable or placing something heavy on the cable, may damage the cable and finally cause a fire or an electrical shock.
- **Do not cover the motor!**
Running a covered motor may accumulate heat inside the motor and cause a fire or a mechanical failure. Ventilate the motor sufficiently.
- **Arrange grounding!**
Do not operate the pump without connecting the grounding wire. Otherwise, an electrical shock may result. Make sure the grounding wire is connected with the grounding terminal.



Caution

- **Install an earth leakage breaker (option)!**
The operation of a pump without using an earth leakage breaker may cause an electrical shock. Please purchase an optional leakage breaker and install in the system.
- **Power cable cannot be replaced.**
Never use a damaged or affected power cable. Otherwise, a fire or an electrical shock may result. Handle the power cable carefully, as it cannot be replaced with a new cable. (The pump unit itself must be replaced in that circumstance.)
- **Limited operating site and storage**
Do not install or store the pump in the following places:
* Places where a flammable gas or material is used or stored.
* Places where the ambient temperature is extremely high (40°C or higher) or extremely low (0°C or lower).
- **Do not drain the liquid in the site.**
The liquid discharged out of the pump, including a hazardous chemical liquid, must be drained into a special container. Never drain such liquid directly onto the floor in or near the operation site.
- **Disposal of used pump**
Disposal of used or damaged pumps must be done in accordance with the relevant local laws and regulations. (Consult a licensed industrial waste products disposing company.)



This instruction manual includes descriptions of the correct handling of the pump, maintenance and inspection procedures and troubleshooting. You are requested to read the manual carefully so that the pump can safely be used to the full extent of its capacity for a long period of time.

Contents

| ■ Item | ■ Page |
|---|----------|
| ① Inspection and Unpacking | 1 |
| ② Principle of operation | 1·2 |
| ③ Pump Identification Codes | 2 |
| ④ Names of Parts and Structure | 3 |
| ⑤ Precautionary Measures | 4·5 |
| ⑥ Installation, Piping and Wiring | 6·7·8·9 |
| ⑦ Operation | 10·11 |
| ⑧ Maintenance and Inspection | 12·13 |
| ⑨ Causes of Trouble and Troubleshooting | 14·15 |
| ⑩ Disassembling and Reassembling | 16·17 |
| ⑪ Performance and Sizes | 18·19·20 |

1 Inspection and Unpacking

Upon unpacking, check the following points to confirm that the product is what you ordered. If you find any discrepancy, please refer to the dealer you placed your order with.

| Iwaki Magnet Gear Pump | |
|---|---------------------|
| MODEL | |
| MAX. CAPACITY | l/min |
| MAX. HEAD | kgf/cm ² |
| SINGLE PHASE INDUCTION MOTOR CAPACITOR-RUN | |
| POLES | SPEED rpm |
| VOLTAGE | V RATING CONT |
| CURRENT | A CAPACITOR |
| OUTPUT | W INSULATION CLASS |
| POWER CONSUMPTION | W |
| FREQUENCY | Hz INDOOR |
| DO NOT RUN PUMP DRY | |
| MFG. NO. | |
| IWAKI CO., LTD. | |

◇ Do the model of the pump, discharge, discharge pressure, voltage, and other items marked on the nameplate represent what you ordered?

◇ Is a hexagonal bar wrench for adjusting the set pressure of the relief valve attached?

◇ Has the product been damaged or nuts and bolts been loosened during delivery? Please examine visually or by touch.



Hexagonal bar wrench

2 Principle of Operation

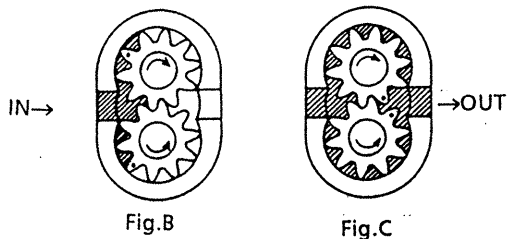
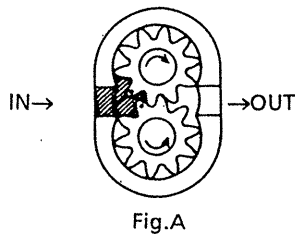

The Iwaki Magnet Gear Pump comprises a pair of gears driven by a magnet coupling and casing in which the gears are fitted exactly. (Fig.A) Liquid introduced from the IN side feeds into the grooves between the teeth of the gears and is transferred to the OUT side by rotation of the gears. (Fig.B)

Then, the liquid is forced out of the grooves between the gear teeth in engagement. (Fig. C)

③ Pump Identification Codes

MDG — $\frac{M}{①}$ $\frac{2}{②}$ $\frac{S}{③}$ $\frac{220}{⑥}$ $\frac{N}{⑦}$ $\frac{L}{⑧}$

MDG — $\frac{M}{①}$ $\frac{2}{②}$ $\frac{S}{③}$ $\frac{6}{④}$ $\frac{B}{⑤}$ $\frac{220}{⑥}$

- ① Pump model
M : Pump with a relief valve
- ② Discharge
2 : 0.7ml /rev
- ③ Application type
S : For positive-pressured discharge
T : For negative-pressured suction
- ④ Maximum discharge pressure
No code : 0.3 MPa 6 : 0.6 MPa
- ⑤ Connection
NO code or B : 1/8 NPT A : Rc 1/8
- ⑥ Line voltage
100 : AC100V 115 : AC115V 220 : AC220~240V
- ⑦ Motor specification
N : N motor is Installed
- ⑧ Non-standard specification code
L : Equipped with a UL - approved motor
No code : Equipped with a standard motor

4 Names of Parts and Structure

- Exploded View
 - MDG - M2T · S model
 - MDG - M2S6 model

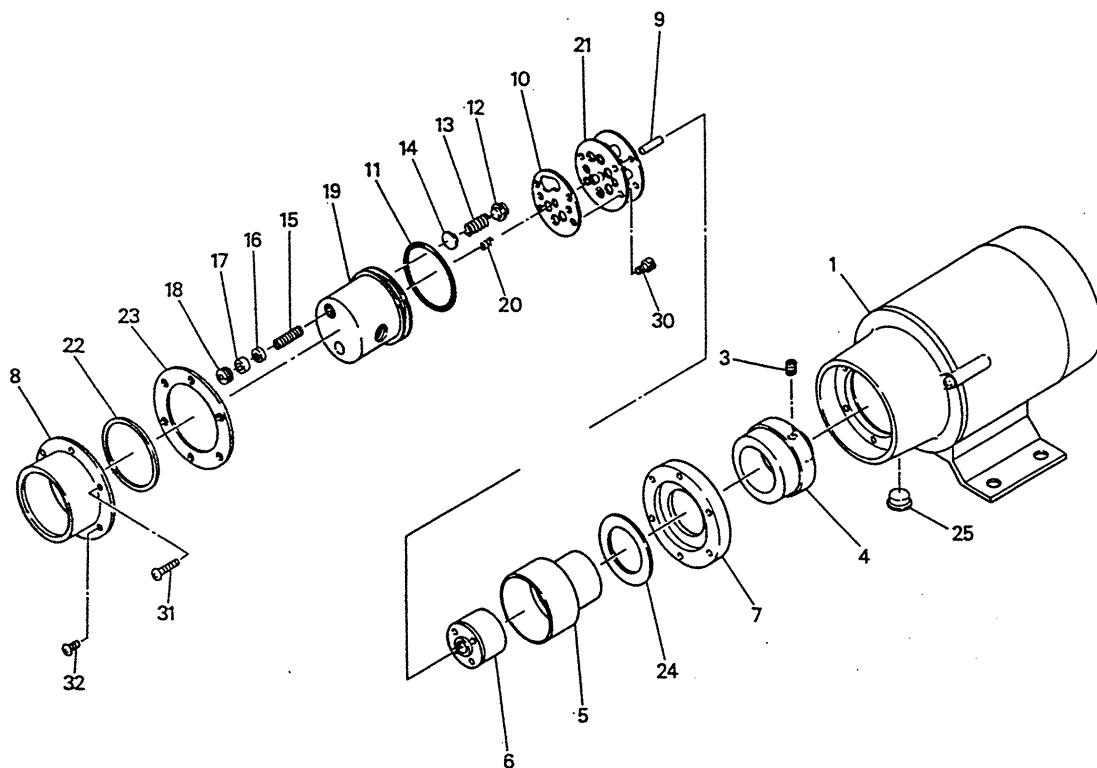

| No. | Name | Number | Remark | No. | Name | Number | Remark |
|-----|-------------------------|--------|--------|-----|---------------------------------------|--------|--------|
| 1 | Motor | 1 | | 16 | Valve gasket | 1 | |
| 3 | Setscrew | 1 | M4×6 | 17 | Clamp spacer | 1 | |
| 4 | Driving magnet assembly | 1 | | 18 | Clamp nut | 1 | |
| 5 | Rear casing | 1 | | 19 | Pump body | 1 | |
| 6 | Magnet capsule | 1 | | 20 | Shaft spring | 1 | |
| 7 | Mounting plate | 1 | | 21 | Gear case unit | 1 | |
| 8 | Bracket | 1 | | 22 | Packing A | 1 | |
| 9 | Driving gear shaft | 1 | | 23 | Packing B | 1 | |
| 10 | Gasket | 1 | | 24 | Packing C | 1 | |
| 11 | O ring | 1 | | 25 | Plug | 1 | |
| 12 | Relief valve | 1 | | 30 | Hexagon socket head bolt | 1 | M3×5 |
| 13 | Spring | 1 | | 31 | Hexagon socket pan-head machine screw | 1 | M3×16 |
| 14 | Spring seat | 1 | | 32 | Hexagon socket pan-head machine screw | 1 | M3×8 |
| 15 | Adjustment screw | 1 | | | | | |

5 Precautionary Measures

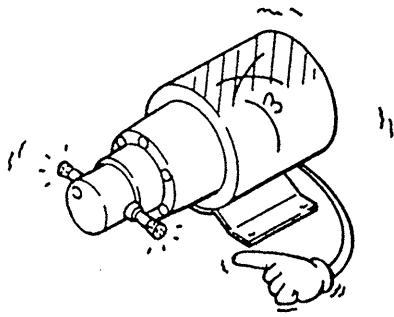

① Do not operate the pump dry or with the discharge or suction side closed. If this is done, the gears and bearings will be worn out. Particularly, if the pump is operated with the discharge side closed, the discharge pressure will be increased and the relief valve will be activated. This will cause the liquid to circulate in the pump chamber. If this happens the temperature will rise rapidly, causing abnormal wear, seizure, etc., between contacting parts.

Discharge pressure

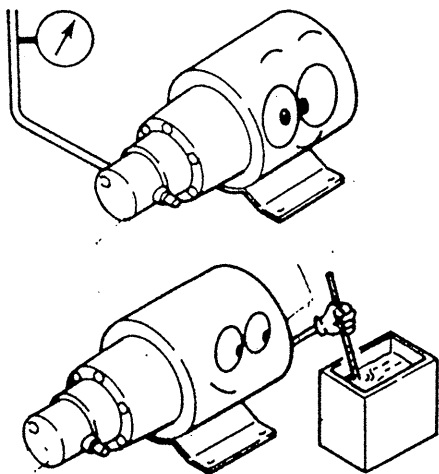

② The maximum discharge pressure is 0.3 MPa or 0.6 MPa

MDG-M2□ N model : 0.3 MPa

MDG-M2S6 model : 0.6 MPa

③ The pump can be used with liquid in the following temperature ranges. The performance will vary depending on the temperature of the liquid.

MDG-M2□ N model : 0~95 °C

MDG-M2S6 model : 0~65 °C

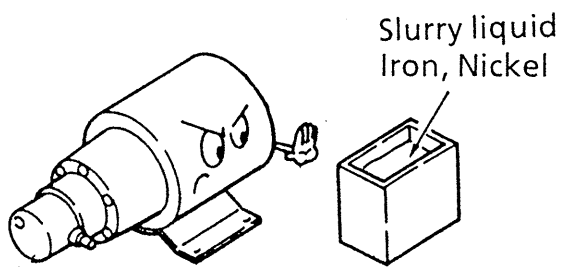

⊠ Since there are powerful magnets inside the pump, any liquid containing powder of iron, nickel, etc. cannot be used. Also, the pump cannot be used for the transfer of slurry liquid or liquid which begins to crystallize when stationary.

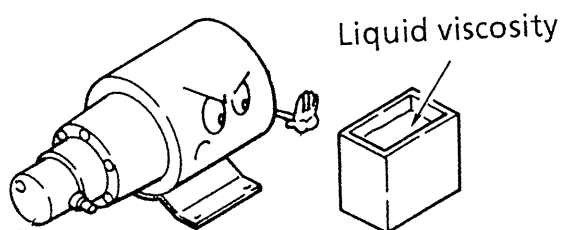

⊠ Please note that highly viscous liquid cannot be transferred with this pump

MDG-M2□N model :

30 mPa·s or lower

MDG-M2S6 model :

50 mPa·s or lower

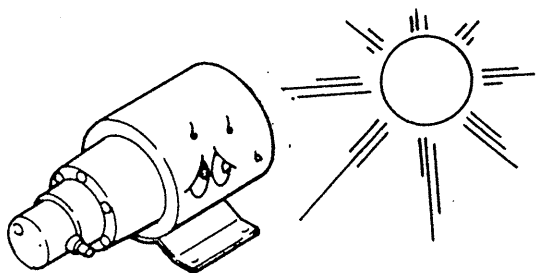

⊠ Do not cover the motor unit tightly with a cover, etc. Avoid operating the pump at an ambient temperature above 40 °C. The relative humidity should be below 85%. Do not splash water on the motor. This may cause an electrical short or burning.

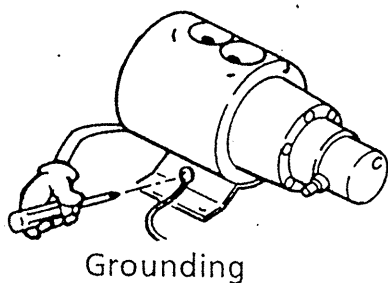

⊠ Grounding must be set with the use of a grounding wire or grounding connection screw (marked E). For the prevention of electric shock, it is recommended that an earth leakage breaker also be installed.

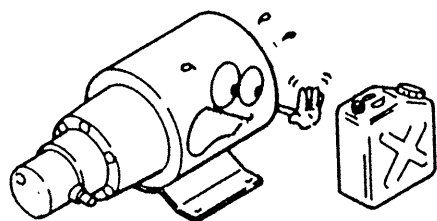

⊠ To ensure safety, do not place any inflammable material or other dangerous substance near the pump.

6 Installation, Piping and Wiring

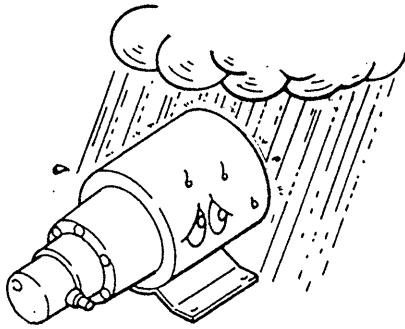

Flooded suction method

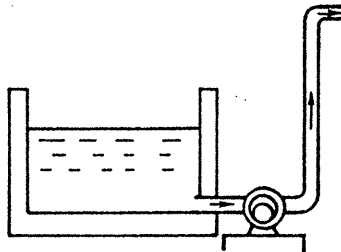

Priming method

(In case the pump chamber is wet)

- ① There is no liquid in the suction piping.
(This is not allowed for the T type.)

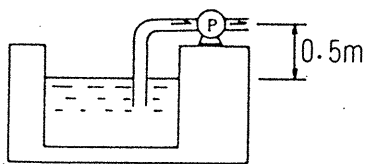

- ② There is liquid inside the suction piping.

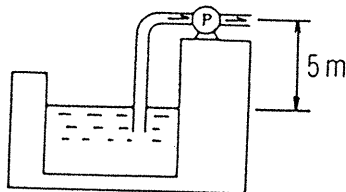

■ Installation

- ① Choose a place which has an ambient temperature below 40°C and a relative humidity less than 85%, and is convenient for maintenance and checking. The pump must not be installed outdoors.

- ② Install the pump in a position lower than the surface of the liquid in the tank on the suction side, to prevent dry running (flooded suction method).

- ③ If it is necessary to install an S type pump in a position in which the inlet of the pump remains higher than the liquid surface (a suction lift), refer to the illustrations on the left. In this position, the pump does not suck unless the pump chamber is wet. (The T type pumps do not function on a suction lift.)

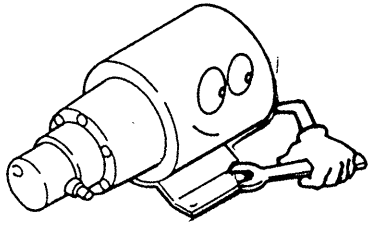

- ④ Use M5 machine screws for fitting the pump. If the floor on which the pump is installed is resonant and causes a loud noise, fix the pump with rubber mountings.

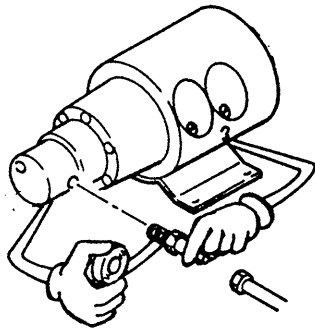

■ Piping

- ④ In order to reduce the friction resistance of liquid, the piping should be as short and with as few bends as possible.

- ④ The inlet and outlet joints of the pump should be completely sealed with sealing tape, etc., to prevent them from sucking air. If the sealing is incomplete on the suction side, in particular, air is sucked in and the performance of the pump is lowered.

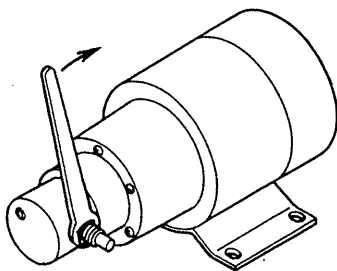

- ④ When screwing the joint to the pump, hold the pump body rather than the motor by hand, to avoid applying excessive force on the motor and pump attachment section. Insert a $\phi 6/5$ round bar into the hole positioned slightly lower than the center of the face of the pump body and hold the round bar so that the excessive force applied to the pump body will be released from there.

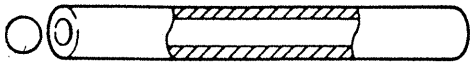

④ For connection, use a thick hose which can withstand pump pressure. Since the hose on the suction side, in particular, tends to be crushed by sucking force, the use of a Teflon hose or something similar is recommended. (When handling hot liquid, special care should be taken.)

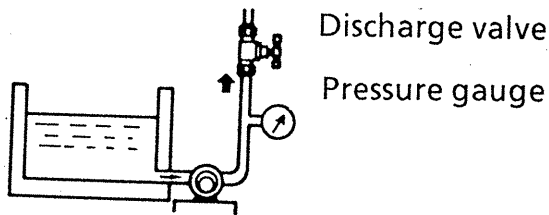

⑤ A pressure gauge must be attached on the discharge piping to case the pressure setting of the relief valve. This attachment also helps in the early detection of pump abnormality.

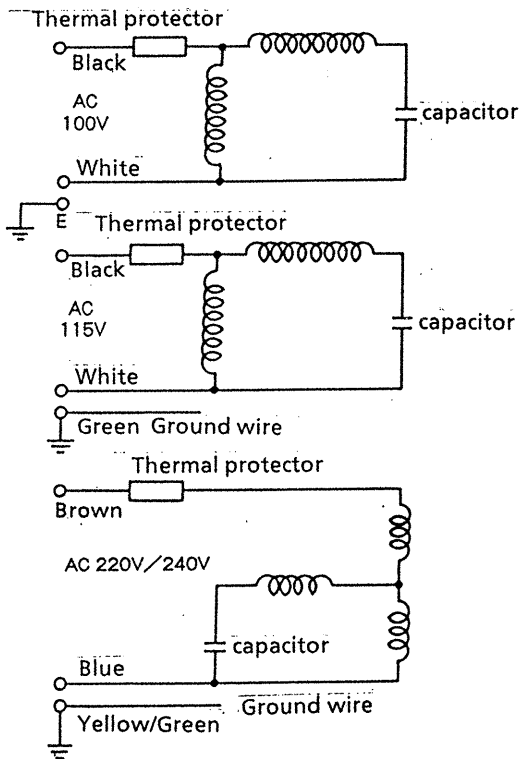

■ Wiring

- ① Use proper wiring elements. Wiring should be carried out in accordance with the technical standard of electric installation and interior wiring regulations, referring to the diagram on the left.
- ② Make sure to include a ground wire or a ground terminal in the wiring.

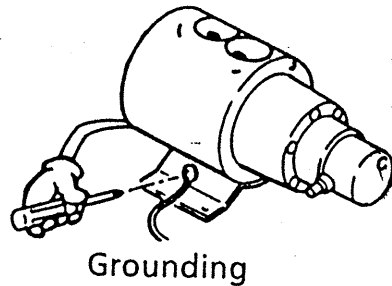

• Rated Electric Current Value · Starting Current Value

50/60Hz

| Model of Pump | Voltage (V) | Rated Current (A) | Starting Current (A) |
|----------------------------------|-----------------|----------------------|-------------------------|
| MDG-M2T100N(L) MDG-M2S100N(L) | 1φ AC100 | 0.5/0.5 | 0.9/0.9 |
| MDG-M2T115N(L) MDG-M2S115N(L) | 1φ AC115 | 0.45/0.45 | 0.7/0.7 |
| MDG-M2S220N | 1φ AC220/240 | 0.23/0.23 | 0.3/0.4 |
| MDG-M2S6B100 | 1φ AC100 | 0.82/0.82 | 1.8/1.9 |
| MDG-M2S6B220 | 1φ AC220~240 | 0.34/0.36 | 0.8/0.9 |
| MDG-M2S6B115 | 1φ AC115 | 0.65/0.69 | 1.6/1.6 |

7 Operation

Dry running is strictly prohibited. This will damage the inside of the pump. Never operate the pump with the valves closed. This will wear away the gears.

■ Operation

After pump installation, piping, and wiring, follow the start-up procedure described below.

| No. | Item | Remarks |
|-----|---|--|
| 1 | Confirmation of piping, wiring, and voltage | <ul style="list-style-type: none"> ● Confirm piping and electrical wiring, referring to descriptions in piping and wiring sections. ● Confirm that line voltage is appropriate, referring to nameplate. |
| 2 | Confirmation of valves | <ul style="list-style-type: none"> ● Valves on suction side and discharge side should be fully opened. |
| 3 | Confirmation of liquid in pump | <ul style="list-style-type: none"> ● When pump is used by lifting method, prime pump sufficiently. |
| 4 | Starting up | <ul style="list-style-type: none"> ● After confirming items 1~3 above, turn ON pump power supply, then check whether liquid is being fed smoothly. If not, immediately turn OFF power supply and eliminate cause of problem, referring to "Causes of Trouble and Troubleshooting" section on page 14. |
| 5 | Operation | <ul style="list-style-type: none"> ● Adjust valve gradually to obtain specified values of discharge, discharge pressure, or degree of vacuum. ● Do not open/close suction port and discharge port suddenly. This may lead to disconnection of magnet coupling, so that gears cannot rotate. If this happens, turn OFF power supply. As motor stops, normal coupling will be restored. ● Do not operate pump with discharge valve and / or suction valve completely or almost completely closed. Set operating pressure to at least 0.1 MPa lower than set value of relief valve pressure. |

| No. | Item | Remarks |
|-----|------------------|---|
| 6 | During operation | <ul style="list-style-type: none"> ● Be careful not to allow any foreign matter to enter pump. Foreign matter may cause gear locking or abnormal wear of gear. ● If earth leakage breaker is actuated, reset it only after carefully examining cause of actuation. Be sure to turn OFF power supply before examining cause. |

■ Relief valve set up

● Relief valve mechanism

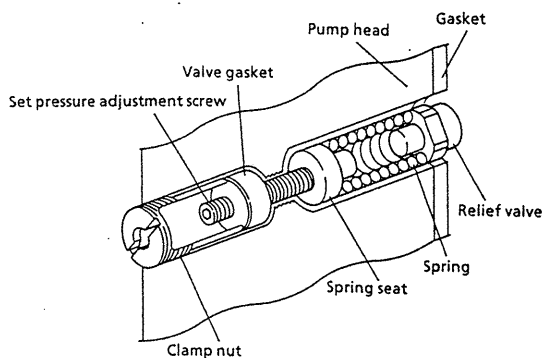

The MDG-M2 model is equipped with a built-in relief valve. The pressure set upon shipping is 0.3 MPa (MDG-M2S model : 0.6 MPa). The pressure value can be adjusted within the range of approximately 0.1~0.4 MPa (MDG-M2S model : 0.2~0.6 MPa). Prior to resetting the pressure, please contact us and follow the procedure described below.

- ① Loosen the clamp nut with a minus screwdriver.
- ② Adjust the pressure for the desired value by turning the set pressure adjustment screw with the attached hexagonal bar wrench. (Watch the pressure gauge installed on the discharge piping in advance for reaching the target value.)
- ③ Fasten the clamp nut tightly with the minus screwdriver.

8 Maintenance and Inspection





■ Daily inspection

Pay attention to the following points while the pump is in operation. If an abnormality occurs, immediately stop the operation and take the appropriate measures by referring to the “Causes of Trouble and Troubleshooting” section on page 14. In addition, observe the replacement timing specified for each consumable part.

| No. | Check Point | Remarks | Check method |
|-----|--|---|--|
| 1 | Is pump lifting liquid properly? | <ul style="list-style-type: none"> ● Whether liquid is being transferred. ● Whether suction and discharge pressures are at normal levels. | <ul style="list-style-type: none"> ● Flow meter or visual check. ● Collation with nameplate. |
| 2 | Is there abnormal noise or vibration? | <ul style="list-style-type: none"> ● If pump does not function normally, abnormal noise or vibration tends to be generated. ● Base on which pump is mounted sometimes becomes resonant to increase noise. If separation of from pump base decreases noise, anti-vibration measure such as attaching anti-vibration rubber mounts to pump should be taken. | <ul style="list-style-type: none"> ● Visual check and hearing check. ● Visual check and hearing check. |
| 3 | Is liquid leaking or air being sucked out from joints of pump? | <ul style="list-style-type: none"> ● Clamp connections more tightly. ● If many air bubbles are found in discharged liquid, air is being sucked out. Examine piping and clamp connection more closely. | <ul style="list-style-type: none"> ● Visual check. |
| 4 | Is temperature of pump unit surface, motor surface, etc., abnormally high? | <ul style="list-style-type: none"> ● Pump unit surface temperature is same as that of liquid handled. ● Temperature of motor surface is within about 40°C above ambient temperature. Sometimes it is too hot to touch, but it is normal if temperature is within this range. | <ul style="list-style-type: none"> ● By touch or by thermometer. |

■ Consumable parts

Replace the consumable parts shown on the table as below at the time shown on the table below.

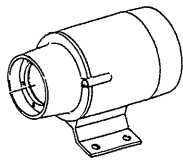
| No. | Parts | | Q'ty | Time to be replaced | Spare kit type |
|-----|------------------|---|-------|---|--|
| 21 | Gear case unit |  | 1 set | 5,000 hours | <ul style="list-style-type: none"> ● SK-M2S for models: MDG-M2SN MDG-M2S6 ● SK-M2T for model: MDG-M2TN |
| 9 | Drive gear shaft |  | 1 | 5,000 hours | |
| 10 | Gasket |  | 1 | 5,000 hours and every time when pump is disassembled. | |
| 11 | O ring |  | 1 | | |
| 1 | Motor |  | 1 | 10,000 hours | |

Note: The time to be replaced mentioned as above means the time when the initial flow rate goes down by 20% when pumping clear water at ambient temperature at discharge pressure of 0.2MPa (0.5MPa for MDG-M2S6). The time to be replaced depends on the characteristics, temperature of pumped liquid and on the pump operating condition.

