



**Chemically Resistant Magnetic Drive Pumps
Which Can Tolerate Severe Operating Conditions**

Chemically Resistant Magnetic Drive Pumps Which Can Tolerate Severe Operating Conditions



Self-Radiating Structure

Through heat-dispersion holes provided in the fixed portions of the impeller and the magnet capsule, the liquid around the spindle and the bearing is forced to circulate so that heat generated by sliding can be reduced effectively. Thus, thermal deformation and melt are prevented. (Except MX-F100)



ETFE Available for Aggressive Chemicals

Carbon fiber reinforced CFRETFE can be used for a variety of application having a superior chemical compatibility.



Robust Structure

All stress bearing portions, such as the front and rear casings, are reinforced by means of ribs to improve the pressure resistance and the mechanical strength of the pump.

The bearing is not only fixed by conventional press fit but is also sandwiched between the abutting portion in the depth of the magnet capsule and the rear end of the impeller to improve its reliability under high temperature. (Except MX-F100)

MX-F402 and F403 models: an unplugging preventive lock pin is adopted for ensuring more steady securing.



Volute Casing Divided Into Two Sections

The MX-F series is the first resin magnet pump which uses the pump casing divided into the front casing and the rear casing to form a vortex chamber as an ideal form. Therefore, the internal leak phenomenon, which means that the liquid getting out of the impeller returns to the pump casing and is suppressed to a minimum and the liquid is efficiently guided to the discharge port to enhance overall efficiency. (Except MX-F400)



Non-Contact Structure

By installing the driving magnet and the driven magnet in an inventive way, the movement of the magnet capsule is controlled by magnetic force to prevent the rear thrust and the rear portion of the bearing coming into contact with each other continuously even during dry running. This structure reduces heat generation and secures lubricant routes. (Except MX-F100)

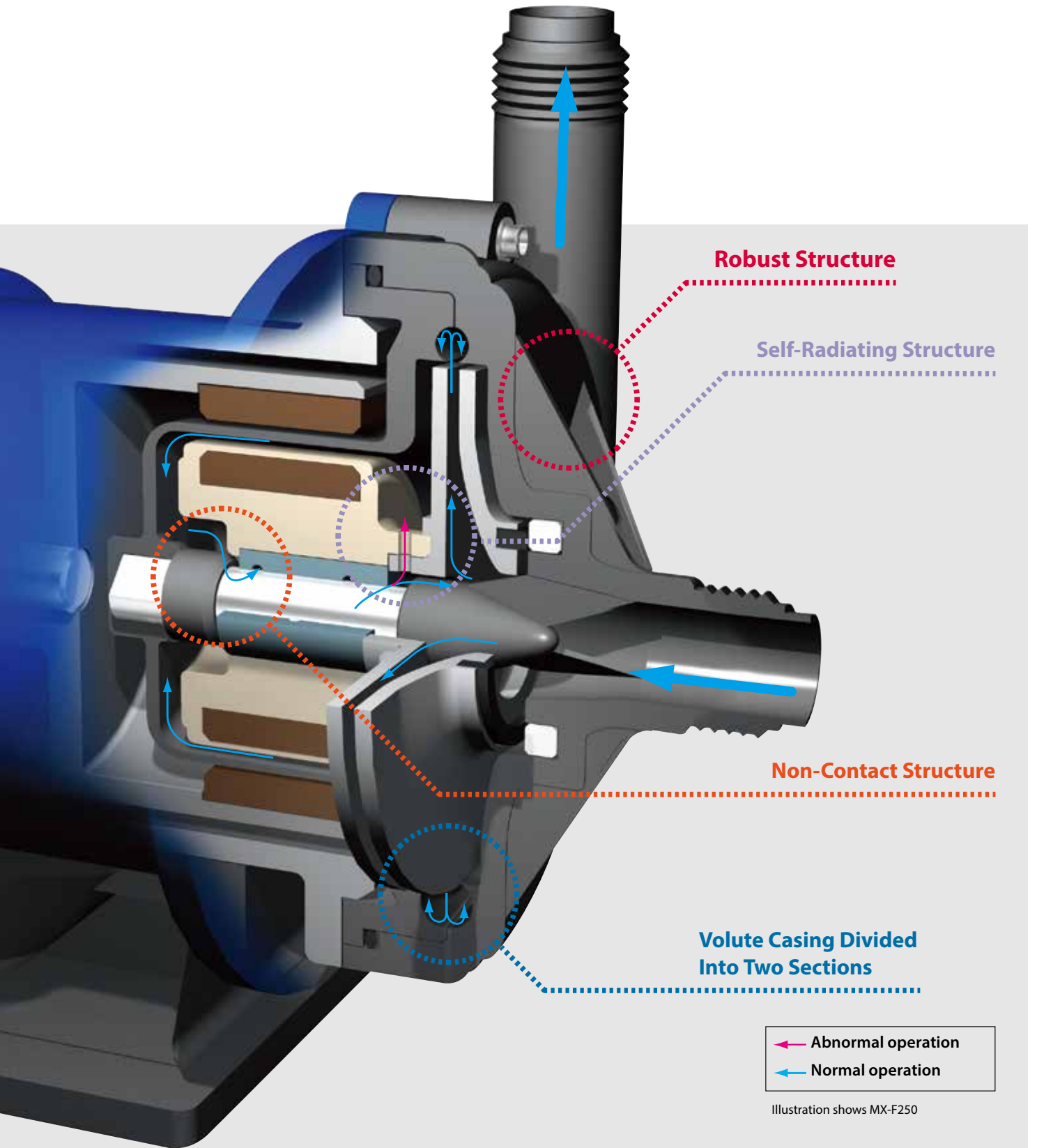

Wet end Materials

MX-F100

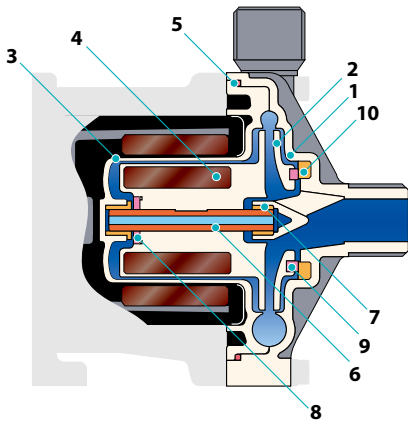

MX-F250 to 401

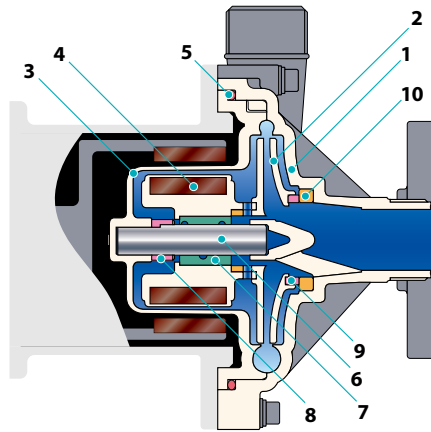

MX-F402 to 403

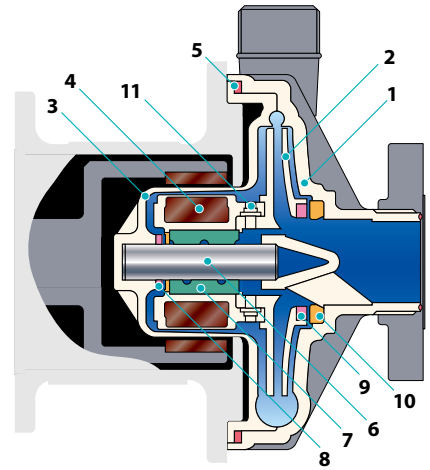

Model	MX-F100		MX-F250 to 401			MX-F402 to 403		
	RV/RE	KV/KE	CFV/CFE	RFV/RFE	KKV/KKE	CFV/CFE	RFV/RFE	KKV/KKE
1 Front casing	CFRETFE		CFRETFE			CFRETFE		
2 Impeller								
3 Rear casing								
4 Magnet capsule								
5 O ring ^{Note 1}	FKM(EPDM)		FKM(EPDM)			FKM(EPDM)		
6 Spindle	High purity alumina ceramic	SiC	High purity alumina ceramic	SiC	High purity alumina ceramic	SiC	High purity alumina ceramic	SiC
7 Bearing	PTFE(with filler)	SiC	High density carbon	PTFE (with filler)	SiC	High density carbon	PTFE (with filler)	SiC
8 Rear thrust	High purity alumina ceramic	SiC(Front & Rear)	CFRETFE			CFRETFE		
9 Mouth ring	PTFE(with filler)	-	PTFE(with filler)		SiC	PTFE(with filler)		SiC
10 Thrust/Liner ring	High purity alumina ceramic	-	High purity alumina ceramic		SiC	High purity alumina ceramic		SiC
11 Lock pin	-		-			CFRETFE		

Note 1: O-ring made of AFLAS® are also available

Pump Identification

MX-F100

MX-F 100 RV M Y
 1 2 3 4 5

- 1 Series symbol
MX-F : Material of Casing/CFRETFE
- 2 Pump size
100 : G1X G1 260W

- 3 Materials of Bearing/O-ring
MX-F RV, RE : PTFE(with filler)/FKM(EPDM)
KV, KE : SiC/FKM(EPDM)
- 4 Connection
M : Thread connection

- 5 Impeller
MX-F Y : 50Hz

MX-F250 to 403

MX-F 401 CFV T E - S
 1 2 3 4 5 6

- 1 Series symbol
MX-F : Material of Casing/CFRETFE
- 2 Pump size
250 : G1 X G1 0.37kW
251 : G1 X G1 0.75kW
400 : G1 1/2 X G1 1/2 0.37kW
401 : G1 1/2 X G1 1/2 0.75kW
402 : G2 X G1 1/2 1.5kW
403 : G2 X G1 1/2 2.2kW

- 3 Material of Bearing/Spindle/O-ring
MX-F CFV, CFE : High density carbon/
 High purity alumina ceramic/FKM(EPDM)
RFV, RFE : PTFE(with filler)/High purity alumina ceramic/
 FKM(EPDM)
KKV, KKE : SiC/SiC/FKM(EPDM)
- 4 Impeller mark
T, T2 ^{Note}, **V, W** : 50Hz

- 5 Motor specification
E : IEC motor
- 6 Special specification:
 No mark : Standard
S : Order-made specification

Note: "T2" means exclusive for IE2 motor. Applicable models are MX-400/401.

Specifications

50Hz

Model	Impeller	Connection Suction X Discharge	Limit of ^{Note 2} specific gravity	Standard capacity L/min - m	Maximum capacity L/min	Motor kW	Mass ^{Note 3} kg
MX-F100 ^{Note 1}	Y	G1 x G1	1.9	70 - 5.8	110	0.26	8.5
MX-F250	T	G1 x G1	1.2	50 - 11.7	150	0.37	8.0
MX-F250	V	G1 x G1	1.5	50 - 9.1	145	0.37	8.0
MX-F250	W	G1 x G1	1.8 to 2.0	50 - 6.4	126	0.37	8.0
MX-F251	T	G1 x G1	1.2	80 - 15.7	150	0.75	8.0
MX-F251	V	G1 x G1	1.5	80 - 12.2	150	0.75	8.0
MX-F251	W	G1 x G1	1.8 to 2.0	80 - 9.4	120	0.75	8.0
MX-F400	T	G1 1/2 x G1 1/2	1.2	100 - 10.1	250	0.37	6.5
MX-F400	T2	G1 1/2 x G1 1/2	1.2	100 - 9.0	250	0.37	6.5
MX-F400	V	G1 1/2 x G1 1/2	1.5	100 - 8.1	230	0.37	6.5
MX-F400	W	G1 1/2 x G1 1/2	1.8 to 2.0	100 - 5.5	210	0.37	6.5
MX-F401	T	G1 1/2 x G1 1/2	1.2	150 - 12.8	270	0.75	10.5
MX-F401	T2	G1 1/2 x G1 1/2	1.2	150 - 12.8	270	0.75	10.5
MX-F401	V	G1 1/2 x G1 1/2	1.5	150 - 10.8	260	0.75	10.5
MX-F401	W	G1 1/2 x G1 1/2	1.8 to 2.0	150 - 8.1	240	0.75	10.5
MX-F402	T	G2 x G1 1/2	1.2	200 - 18.3	440	1.5	14.0
MX-F402	V	G2 x G1 1/2	1.5	200 - 16	430	1.5	14.0
MX-F402	W	G2 x G1 1/2	1.8 to 2.0	200 - 12.5	410	1.5	14.0
MX-F403	T	G2 x G1 1/2	1.2	250 - 22.8	510	2.2	15.0
MX-F403	V	G2 x G1 1/2	1.5	250 - 19.4	500	2.2	15.0
MX-F403	W	G2 x G1 1/2	1.8 to 2.0	250 - 15.3	470	2.2	15.0

Note 1: MX-F100 performance data and Mass kg are based on using Iwaki standard motor.

The motor to be mounted is an IEC motor.

Note 2: The specific gravity limit varies with the discharge. For details, please contact us.

Note 3: Less motor except MX-F100.

Common specifications

• Range of liquid temperature : 0 to 80°C (10 to 80°C in case AFLAS® O-rings are used.) • Range of ambient temperature : 0 to 40°C.

Precautions for pump selection

1. The performance curves on this catalogue are based on clean water of 20 °C.
Keep a margin (3% of the curves) when selecting the pump.

2. For the MX-F250 or larger models, select a proper impeller size according to specific gravity. Always keep 10% allowance to motor output.

Applicable motor output

$$Sp \times S.G \times (1.1) \leq \frac{\text{Motor output}}{\text{Allowance}}$$

3. The magnetic drive pump is not durable for a long time in closed-discharge operation. Always keep the minimum flow.

Minimum flow

MX-F100, 250, 251, 400, 401: 10 L/min
MX-F402, 403: 20 L/min

4. NPSH validation
Observe the following for the prevention of cavitation.

$$NPSHa \geq NPSHr + 0.5 \text{ m} \frac{\text{Allowance}}{\rho g}$$

$$NPSHa = \frac{(Pa - Pv) \times 10^6}{\rho g} \pm hs - hfs$$

5. Maximum withstand pressure

MX-F100: 0.19MPa MX-F400: 0.22MPa
MX-F250: 0.25MPa MX-F401: 0.28MPa
MX-F251: 0.33MPa MX-F402: 0.43MPa
MX-F403: 0.43MPa

NPSHa: Net Positive Suction Head Available (m)
NPSHr: Net Positive Suction Head Required (m)
Pa: Pressure on the suction liquid level (MPa) (Absolute pressure)
Pv: Pressure of saturated vapor (MPa)
hs: Static suction head (m)
hfs: Suction pipe resistance (m)
 ρ : Liquid density (kg/m³)
g: G-force (9.8m/sec²)

Performance Curves

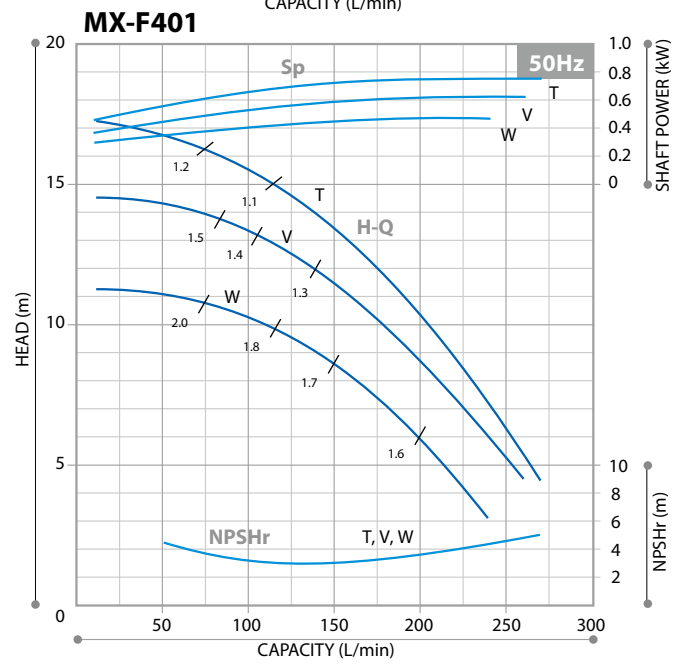
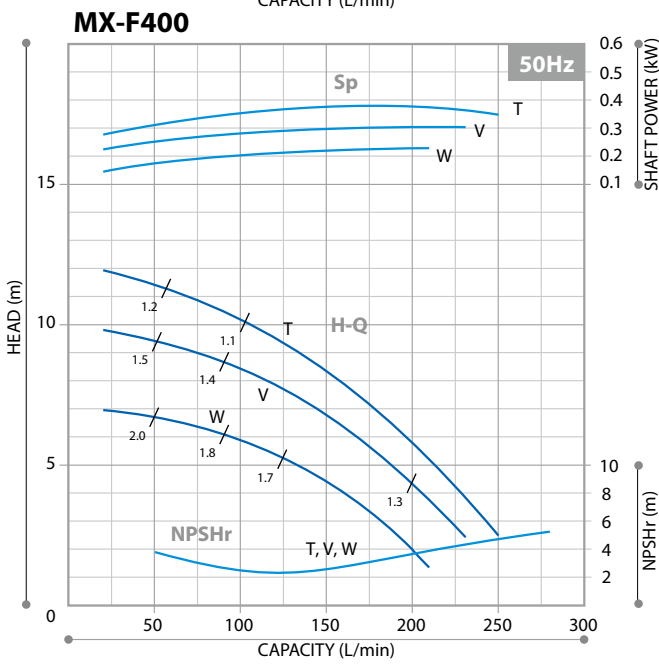
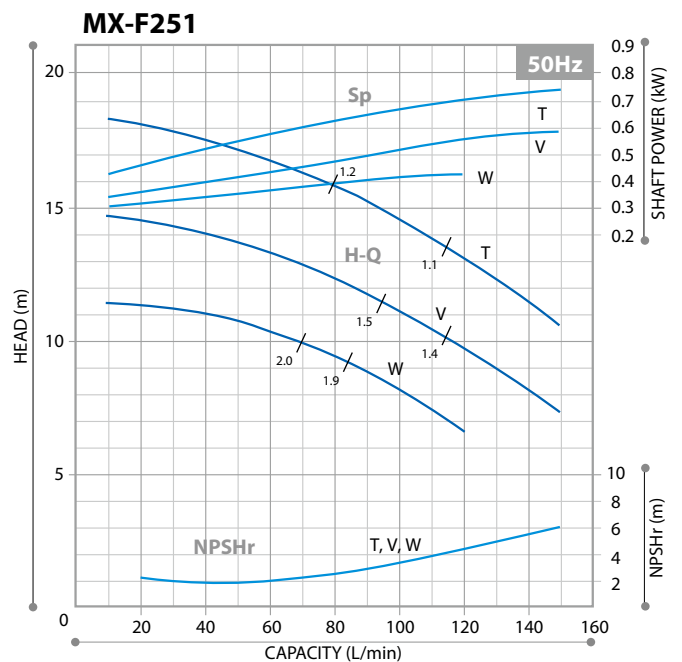
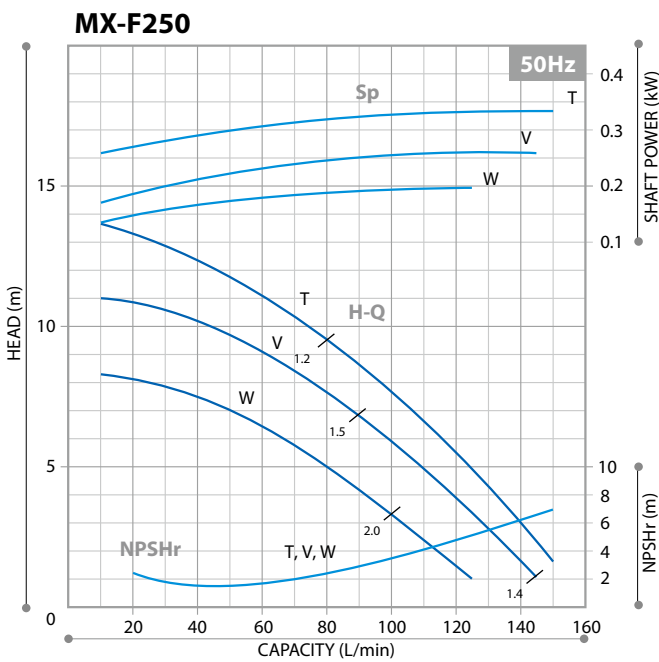
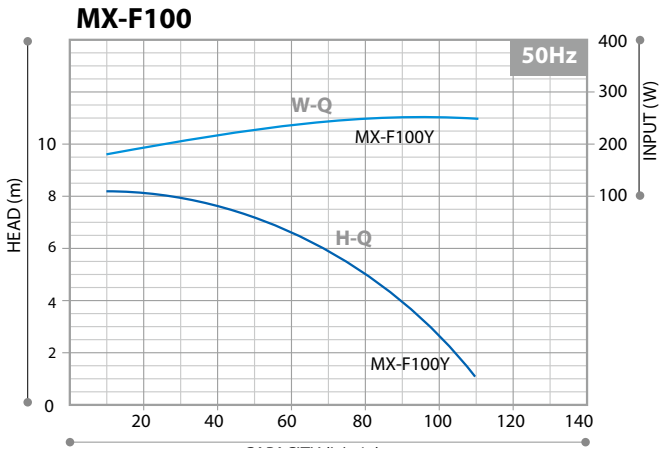

Note: The specific gravity limit described in the head is only a guide and please contact us for details.

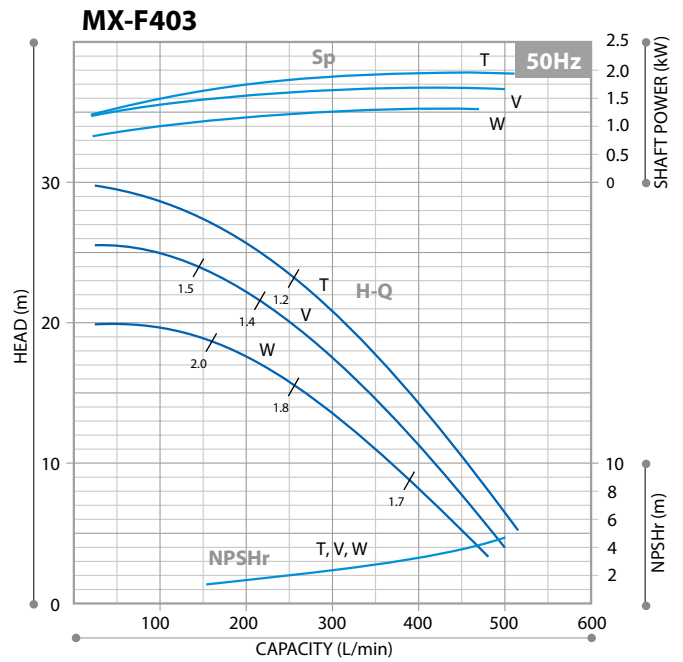
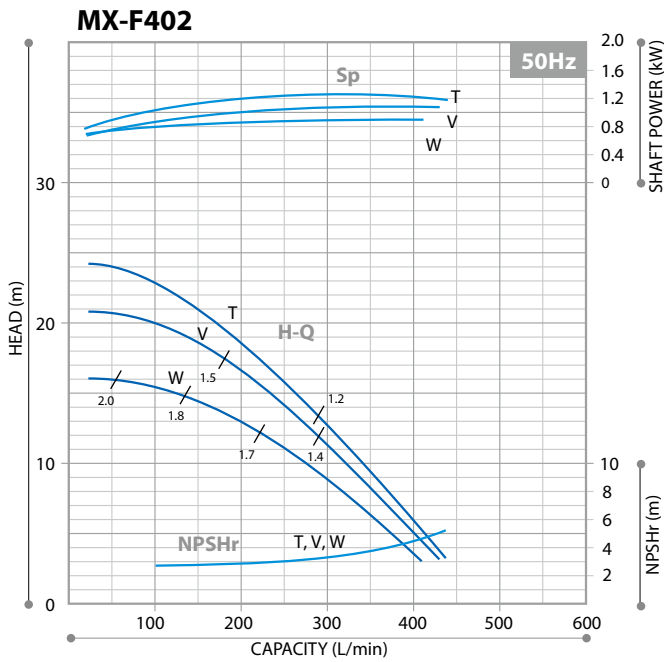

Dimensions (mm)

MX-F100 Note 1

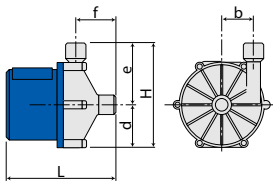

MX-F250 to 401

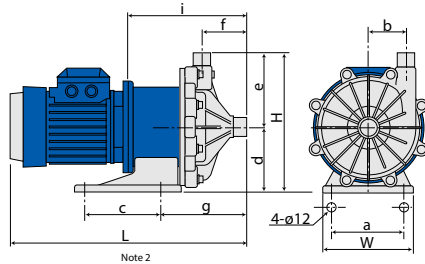

MX-F402, 403

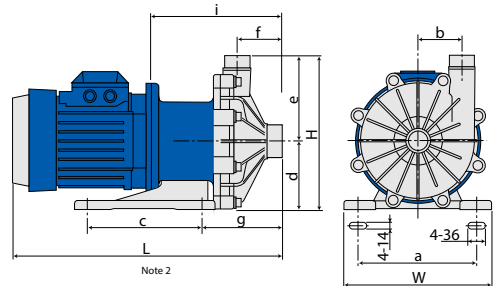

Models	W	H	L	a	b	c	d	e	f	g	i
MX-F100	-	169	177	-	51	-	69	100	65	-	-
MX-F250	160	247.5	-	130	65	130	115	132.5	82.5	155.5	213.5
MX-F251	160	247.5	-	130	65	130	115	132.5	82.5	163.5	225.5
MX-F400	140	219	-	110	54	98	95	124	81	144	215
MX-F401	160	249	-	130	72	130	115	134	97	178	240
MX-F402 to 403	260	274	-	208	80	200	120	154	83	151	235

Note 1: The MX-100 outer dimensions are without a motor. For the motor mounting dimensions, please contact us.

Note 2: The dimensions L may differ with the type of motor installed.

Optional Accessories

IWAKI Pump Protector DRN Series

Detects Unusual Pump Operating Conditions Including Dry-Running and Overload

The DRN model protects equipment (including pumps) from damage!

Minimizes production downtime.

Identifies possible causes of alarms so they can be investigated and addressed.

- Multiple Input Two analog, one digital, one temperature input and one current input
- Easy operation Equipped with EASY setup mode to remember the operation status and set the lower/upper limit values, as well as AUTO setup mode
- Bar graph Visible indication of current operating status
- Logging capability Data log feature for preventative maintenance scheduling
- Communication RS485 external communication capability



Specifications

Model	DRN-01	DRN-02
Amperometric range	0.5-30.00A	5.0-200.0A
Unit's source voltage	AC100-240V 50/60Hz 10VA	
Operating temperature	0-40°C	
Operating humidity	35-85%RH	

IWAKI Process Magnetic Drive Pump Series

MX Series

Withstands Difficult Operating Conditions and Offers High Efficiency

Max. discharge capacity: 500 L/min
Max. discharge head: 35 m
Main materials: GFRPP



SMX Series

Versatile Self-Priming Magnetic Drive Pump with Enhanced Durability Under Abnormal Operation

Max. discharge capacity: 440 L/min
Max. head: 25.5 m
Main materials: GFRPP, CFRETFE



MXM Series

Magnetic Drive Pumps with an Excellent Balance of Features and Performance

Max. discharge capacity: 600 L/min
Max. head: 29 m
Main materials: CFRETFE



MDM Series

Magnetic Drive Processing Pump with Dry Running Capability

Max. discharge capacity: 1800L/min
Max. head: 74 m
Main materials: CRETFE, PFA



IWAKI CO., LTD. 6-6 Kanda-Sudacho 2-chome Chiyoda-ku Tokyo 101-8558 Japan TEL : (81)3 3254 2935 FAX : 3 3252 8892

IWAKI has global net work. Please find your distributor location at

www.iwakipumps.jp

European Headquarter Germany	IWAKI Europe GmbH TEL: (49)2154 9254 0	FAX: (49)2154 9254 48	U.S.A.	IWAKI America Inc. TEL: (1)508 429 1440	FAX: (1)508 429 1386
The Netherlands (Netherlands Branch)	IWAKI Europe GmbH TEL: (31)74 2420011	FAX: (49)2154 9254 55	Brazil	IWAKI Do Brasil Comercio De Bombas Hidraulicas LTDA. TEL: (55)19 3244 5900	FAX: (55)19 3244 5900
Italy (Italy Branch)	IWAKI Europe GmbH TEL: (39)0445 561219	FAX: (49)2154 9254 48	China (Shanghai)	IWAKI Pumps (Shanghai) Co., Ltd. TEL: (86)21 6272 7502	FAX: (86)21 6272 6929
Spain (Spain Branch)	IWAKI Europe GmbH TEL: (34)934 741 638	FAX: (39)0445 569088	China (Hong Kong)	IWAKI Pumps Co., Ltd. TEL: (852)2607 1168	FAX: (852)2607 1000
Poland (East Europe Branch)	IWAKI Europe GmbH TEL: (48)12 347 0755	FAX: (34)934 741 638	China (Guangzhou)	GFTZ IWAKI Engineering & Trading Co., Ltd. TEL: (86)20 84350603	FAX: (86)20 84359181
Denmark	IWAKI Nordic A/S TEL: (45)48 242345	FAX: (48)12 347 0900	Singapore	IWAKI Singapore Pte Ltd. TEL: (65)6316 2028	FAX: (65)6316 3221
Finland	IWAKI Suomi Oy TEL: (358)10 201 0490		Indonesia (Indonesia Office)	IWAKI Singapore Pte Ltd. TEL: (62)21 6906606	FAX: (62) 21 6906612
Norway	IWAKI Norge AS TEL: (47)23 38 49 00		Malaysia	IWAKim SDN. BHD. TEL: (60)3 7803 8807	FAX: (60)3 7803 4800
Sweden	IWAKI Sverige AB TEL: (46)8 511 72900		Korea	IWAKI Korea Co.,Ltd. TEL: (82)2 6238 4800	FAX: (82)2 6238 4801
Belgium	IWAKI Belgium N.V. TEL: (32)13 670200	FAX: (32)13 672030	Taiwan	IWAKI Pumps Taiwan Co., Ltd. TEL: (886)2 8227 6900	FAX: (886)2 8227 6818
France	IWAKI France S.A. TEL: (33)1 69 63 33 70	FAX: (33)1 64 49 92 73	Thailand	IWAKI (Thailand) Co.,Ltd. TEL: (66)2 322 2471	FAX: (66)2 322 2477
			Australia	IWAKI Pumps Australia Pty Ltd. TEL: (61)2 9899 2411	FAX: (61)2 9899 2421

() Country codes

Caution for safety use: Before use of pump, read instruction manual carefully to use the product correctly. Actual pumps may differ from the photos. Specifications and dimensions are subject to change without prior notice. For further details please contact us.

Legal attention related to export. Our products and/or parts of products fall in the category of goods contained in control list of international regime for export control. Please be reminded that export license could be required when products are exported due to export control regulations of countries. The posting and copying from this catalogue without permission is not accepted firmly.