



Air Pumps &
Gas and Liquid Transfer Pumps
DC MOTOR **APN/APN-W**



Extensive Product Range
Wide Variation
Application Flexibility

The Heart of Industry

Diaphragm Air Pumps APN

Suitable for Built-in
Equipment.
Diaphragm Air Pump.



Clean Air Transfer

A diaphragm pump directly connected to the motor provides clean air transfer without the use of oil. Ideal for medical, sampling, and other applications in which clean air needs.



High Efficiency Design

A use of molded parts enhances the pump performance and efficiency. The high-power motor also improves the starting characteristic.



Superior Durability

Fiber reinforced diaphragms, enlarged bearings and enhanced connecting rods have further improved reliability and durability in order for the pump to run over an extended period of time in a continuous operation.



Ease of Maintenance

The pump head consists of only a few parts and can easily be assembled and disassembled.*

*Excluded some models.

Application Examples

Analyzers

Medical analyzers (biochemical analyzers [for medical waste liquor/washings collection]), environmental analyzers (spectral photometers [for material adsorption], leak testers, dust counters)



Laboratory

Aspirators, liquid chromatography, particle counters, leak testers, sprays, culture apparatus, aseptic baths.

Gas and Liquid Transfer Pumps

APN-W

Maintaining the Features of the APN Series.
Lightweight and Compact Design.
Gas-Liquid Transfer Capability.



Compact and Lightweight

A compact and lightweight design is used that is perfect fit for built-in applications and for waste recovery. A structure with high corrosion resistance and enhanced reliability / durability enables continuous operation for an extended period of time and ensures long life.



Oil-Free Design Self-Priming Capability

The motor-driven diaphragm pumps are oil-free and are most suitable for usage requiring clean gas and liquid transfer. A wide variety of models are available for various usage. Self-priming capability makes end user's piping easily.



V-Shaped Valve Flush Groove

To improve sealing performance even when the valve is stationary, a V-shaped valve is designed to be pressed against the valve seat. A flush groove design is adapted in the valve seat to prevent accumulating debris when the debris is accidentally mixing in the pumped liquid. The flush groove helps to prevent accumulating the debris between the valve and the valve seat.



Diaphragm Durability

The diaphragm is made thick regarding its moving parts, in order to withstand the pump pressure in gas-liquid transferring.



Medical

Aspirators, nebulizers, low-frequency therapy equipment, blood-pressure gauges, endoscopes, X-ray film adsorption/transfer equipment, gas sterilizers, tappers, artificial respirators, interferential current therapy equipment, normal saline solution sprays, massagers, pressurization/ vacuum sources for various devices



Specifications

APN Diaphragm Air Pumps

Model	Gas Max. flow			Max. Vacuum	101.32 79.98	Max. Discharge pressure			
	1.0	10.0	30.0 L/min			kPa	26.66	0.02	0.06
S041 Brushless motor	[Bar chart: ~1.0 L/min]			0.8	9.33	[Bar chart: 0.02 MPa]			0
051 Brushless motor	[Bar chart: ~1.0 L/min]			1.0	61.32	[Bar chart: 0.02 MPa]	[Bar chart: 0.06 MPa]		0.05
085 Brushed motor	[Bar chart: ~6.0 L/min]			6.0	61.32	[Bar chart: 0.02 MPa]	[Bar chart: 0.06 MPa]		0.08
110 Brushless motor	[Bar chart: ~14.0 L/min]			14.0	23.99	[Bar chart: 0.02 MPa]	[Bar chart: 0.06 MPa]	[Bar chart: 0.10 MPa]	0.10
P110 Brushless motor	[Bar chart: ~28.0 L/min]			28.0	23.99	[Bar chart: 0.02 MPa]	[Bar chart: 0.06 MPa]	[Bar chart: 0.10 MPa]	0.10

APN-W Gas and Liquid Transfer Pumps

Model	Gas-liquid Max. capacity		Gas Max. flow	Max. Vacuum	101.32 79.98	Max. Discharge pressure			
	1.0	10.0				30.0 L/min	kPa	26.66	0.02
05 Brushed motor	[Bar chart: ~0.05 L/min]		0.05	87.99			[Bar chart: 0.02 MPa]		0.01
10 Brushed motor	[Bar chart: ~0.1 L/min]		0.1	74.66			[Bar chart: 0.02 MPa]	[Bar chart: 0.06 MPa]	0.03
	[Bar chart: ~0.2 L/min]		0.2	74.66			[Bar chart: 0.02 MPa]	[Bar chart: 0.06 MPa]	Note1 0.03
20 Brushless motor	[Bar chart: ~0.18 L/min]		0.18	74.66			[Bar chart: 0.02 MPa]	[Bar chart: 0.06 MPa]	Note1 0.03
	[Bar chart: ~0.2 L/min]		0.2	74.66			[Bar chart: 0.02 MPa]	[Bar chart: 0.06 MPa]	Note1 0.03
30 Brushed motor	[Bar chart: ~0.3 L/min]		0.3	47.99			[Bar chart: 0.02 MPa]	[Bar chart: 0.06 MPa]	0.08
	[Bar chart: ~1.2 L/min]		1.2	47.99			[Bar chart: 0.02 MPa]	[Bar chart: 0.06 MPa]	0.08
60 Brushless motor	[Bar chart: ~0.3 L/min]		0.3	47.99			[Bar chart: 0.02 MPa]	[Bar chart: 0.06 MPa]	0.08
	[Bar chart: ~1.0 L/min]		1.0	47.99			[Bar chart: 0.02 MPa]	[Bar chart: 0.06 MPa]	0.08
P60 Brushless motor	[Bar chart: ~0.6 L/min]		0.6	47.99			[Bar chart: 0.02 MPa]	[Bar chart: 0.06 MPa]	0.08
	[Bar chart: ~1.2 L/min]		1.2	47.99			[Bar chart: 0.02 MPa]	[Bar chart: 0.06 MPa]	0.08
085 Brushed motor	[Bar chart: ~0.6 L/min]		0.6	47.99			[Bar chart: 0.02 MPa]	[Bar chart: 0.06 MPa]	0.08
	[Bar chart: ~1.0 L/min]		1.0	47.99			[Bar chart: 0.02 MPa]	[Bar chart: 0.06 MPa]	Note2 0.08
085 Brushed motor	[Bar chart: ~0.5 L/min]		0.5	34.66			[Bar chart: 0.02 MPa]	[Bar chart: 0.06 MPa]	0.05
	[Bar chart: ~4.0 L/min]		4.0	34.66			[Bar chart: 0.02 MPa]	[Bar chart: 0.06 MPa]	0.05

Note1: Max. discharge pressure of the gas-liquid transfer is 0.1MPa.

Note2: Max. discharge pressure of the gas-liquid transfer is 0.05MPa.

APN-S041

P. 5, 6



APN-085

P. 9, 10



APN-110

P. 11, 12



APN-051

P. 7, 8



Model		Power consumption (W) DC12/24	Rated current (A) DC12/24	Rated voltage (V)	Connection size IN/OUT (mm)	Mass (kg)	Allowable gas temp. (°C)	Allowable ambient temp. (°C)	Limit cold start temperature (°C)
S041	Brushless motor	-/6	-/0.25 or less	DC24	Hose Ø4.5	0.4	0 to 40	0 to 40	0
051	Brushless motor	-/6	-/0.25	DC24	Hose Ø8, Thread Rc1/8	0.5	5 to 40	5 to 40	5
085	Brushed motor	19/19	1.6/0.8	DC12/24	Hose Ø8, Thread Rc1/4, G1/4	1.1	0 to 40	0 to 40	10
110	Brushless motor	-/33.6	-/1.4	DC24		1.4		5 to 40	5
P110	Brushless motor	-/55.2	-/2.3			3.3			

Model		Power consumption (W) DC12/24	Rated current (A) DC12/24	Rated voltage (V)	Connection size IN/OUT (mm)	Mass (kg)	Allowable gas temp. (°C)	Allowable liquid temp. (°C)	Limit cold start temperature (°C)
05	Brushed motor	4.8/4.8	0.4/0.2	DC12/24	Hose Ø4.5	0.11	5 to 40	10 to 40	5
	Brushed motor								
10	Brushless motor	-/7.2	-/0.3	DC24		0.2			
	Brushed motor	-/4.8	-/0.2			Hose Ø5			
20	Brushless motor	-/7.2	-/0.3	DC24	0.2				
	Brushed motor	-/11.5	-/0.48		Hose Ø5.5	0.21			
30	Brushless motor	-/14.4	-/0.6	DC24		0.24			
	Brushed motor	-/11.5	-/0.48		Hose Ø5.5	0.21			
60	Brushless motor	-/14.4	-/0.6	DC24		0.24			
	Brushless motor	-/20.6	-/0.86						
P60	Brushless motor	-/20.6	-/0.86						
085	Brushed motor	19/19	1.6/0.8	DC12/24	Thread Rc1/8	2.5	0 to 40	5 to 40	FKM: 10 EPDM: 5

Liquid temperature at 20°C

APN-05/10/20-W

P. 13, 14

**APN-30/60-W**

P. 15, 16

**APN-085-W**

P. 17, 18



APN-S041

Diaphragm Air Pumps

Max. flow 0.8 L/min

Max. vacuum 9.33 kPa(abs.)



Observe the maximum allowable discharge pressure of 0.0MPa.

Specifications

Model	Max. flow (L/min)	Max. vacuum (kPa[abs.])	Power consumption (W)	Rated current (A)	Rated voltage (V)
APN-S041ME-D3 *	0.8	9.33	6.0	0.25 or less	DC24
APN-S041ME-D4 *					

Connection size IN/OUTHose barb Ø4.5mm

Mass0.4kg

Allowable gas temp.0 to 40°C

Allowable ambient temp.0 to 40°C

Minimum starting temperature ...0°C

* D3: 2 wire, D4: 4 wire

Construction and Materials

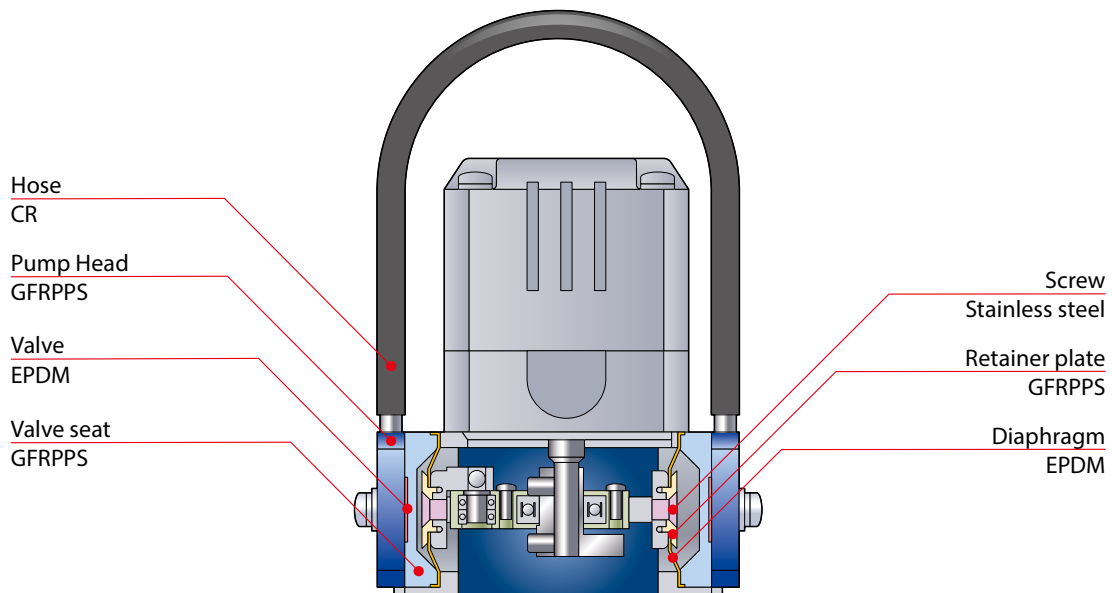

Pump Identification

APN - S 041 M E - D4 - 01

1 2 3 4 5 6 7

1 Pump head
S : Dual-head
with in-line tubing

2 Pump size
041

3 Type
M : Vacuum

4 Diaphragm/Valve materials
E : EPDM

5 Pump connection
No symbol: Hose barb (ø4.5)

6 Motor
D3 : Brushless 24VDC
(without speed control)
D4 : Brushless 24VDC
(with Variable speed control)

7 Special version

Performance Curves

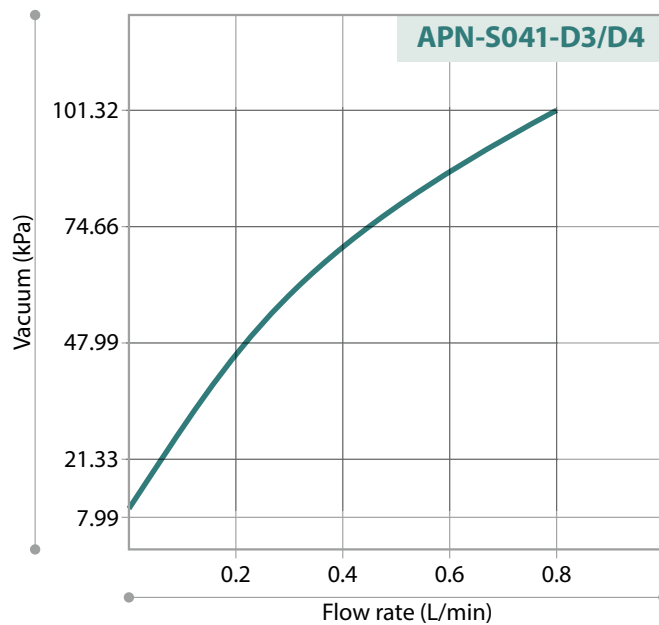

Dimensions in mm

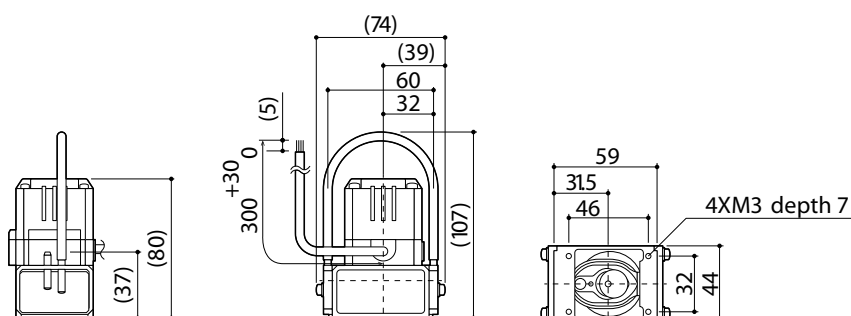

APN-051

Diaphragm Air Pumps

Max. flow 1.0 L/min
Max. vacuum 61.32 kPa(abs.)
Max. discharge pressure 0.05 MPa



Specifications

Model	Max. flow (L/min)	Max. vacuum (kPa[abs.])	Max. discharge pressure (MPa)	Power consumption (W) DC24	Rated current (A) DC24	Rated voltage (V)
APN-051	1.0	61.32	0.05	6	0.25	DC24

Connection size IN/OUTHose barb Ø5mm, Ø8mm, Thread Rc1/8

Mass0.5kg

Allowable gas temp.0 to 40°C

Allowable ambient temp.0 to 40°C

Minimum starting temperature ... 5°C

Construction and Materials

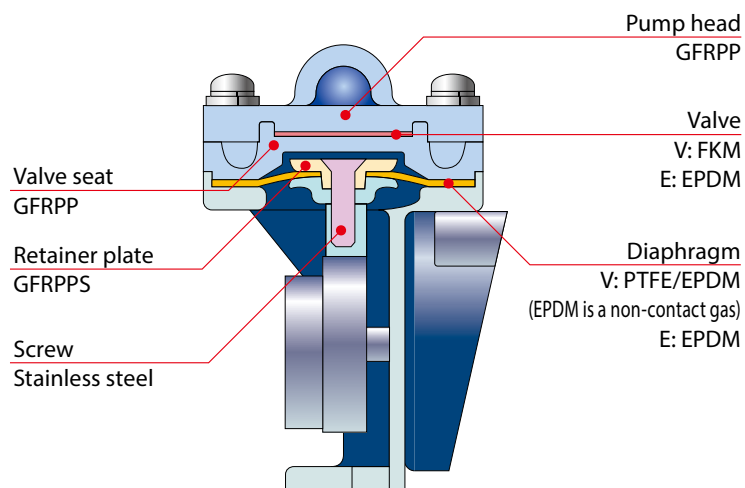

Pump Identification

APN - 051 L E X - D3 - 01

1 2 3 4 5 6

1 Pump size
051

2 Pump head
L : Horizontally oriented
H : Vertically oriented

3 Diaphragm/Valve materials
V : PTFE/EPDM • FKM
E : EPDM • EPDM

4 Pump connection
No symbol: Hose barb (Ø8)
X : Thread (Rc1/8)

5 Motor
D3 : Brushless 24VDC
(without speed control)

6 Special version

Performance Curves

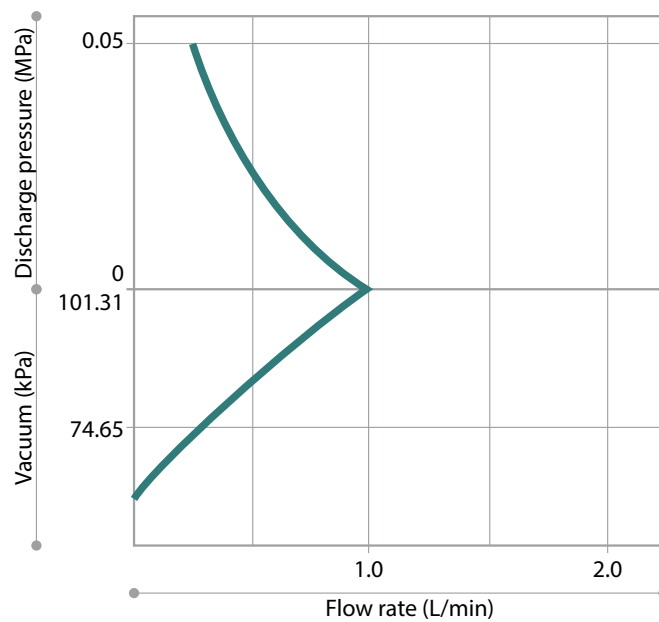

Dimensions in mm

APN-051L (lateral direction)

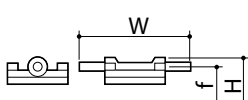

APN-051H (longitudinal direction)

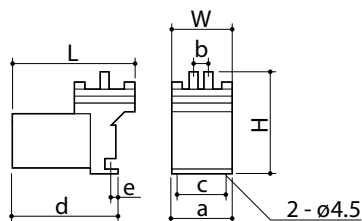

Model	W	H	L	a	b	c	d	e	f
APN-051L	86	(75)	(90)	46	—	32	(76)	6.5	(67)
APN-051H	46	(78)	—	46	13	32	—	6.5	—

APN-085

Diaphragm Air Pumps

Max. flow 6 L/min

Max. vacuum 34.66 to 61.32 kPa(abs.)

Max. discharge pressure 0.08 MPa



Specifications

Model	Max. flow (L/min)	Max. vacuum (kPa)	Max. discharge pressure (MPa)	Power consumption (W) DC12/24	Rated current (A) DC12/24	Rated voltage (V)
APN-085-D1/D2	6	61.32	0.08	19/19	1.6/0.8	DC12/24
APN-085L/H-D1/D2		34.66				

Connection size IN/OUT Hose Ø8mm, Thread Rc1/4, G1/4

Mass 1.1kg

Allowable gas temp. 0 to 40°C

Allowable ambient temp. 0 to 40°C

Minimum starting temperature ...10°C

Construction and Materials

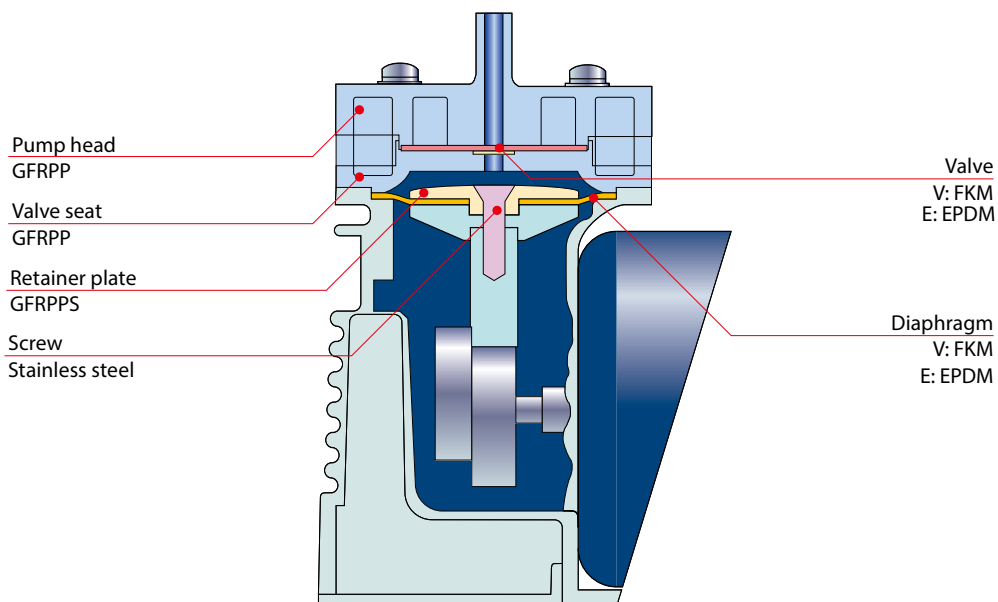

Pump Identification

APN - 085 L V X - D2 - 01

1 2 3 4 5 6

1 Pump size
085

2 Pump head
No symbol: Corrosion resistant
L: Horizontally oriented
H: Vertically oriented

3 Diaphragm/Valve materials
E: EPDM
V: FKM

4 Pump connection
No symbol: Tube (ø8)
X: Thread (Rc1/4)
X1: Thread (G1/4)

5 Motor
D1: Brushed 12VDC
D2: Brushed 24VDC

6 Special version

Performance Curves

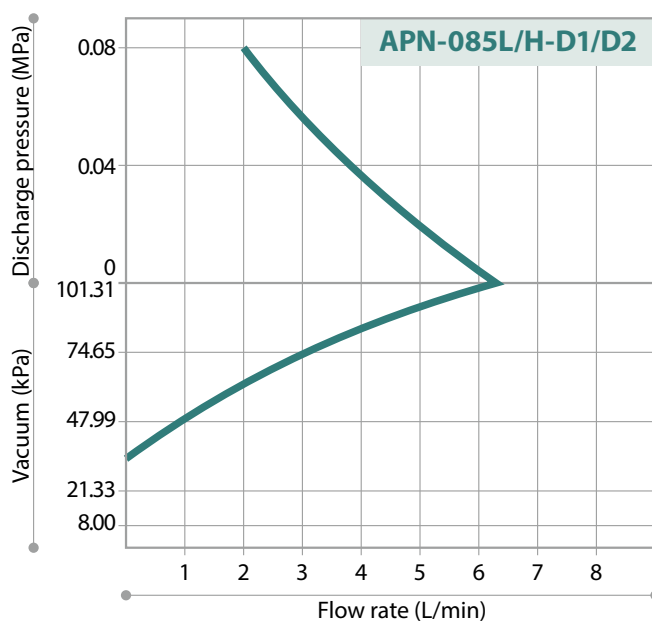
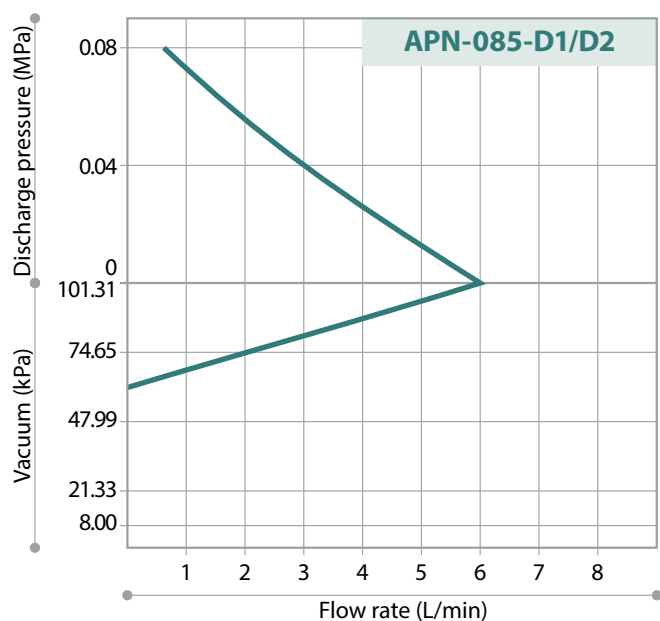

Dimensions in mm

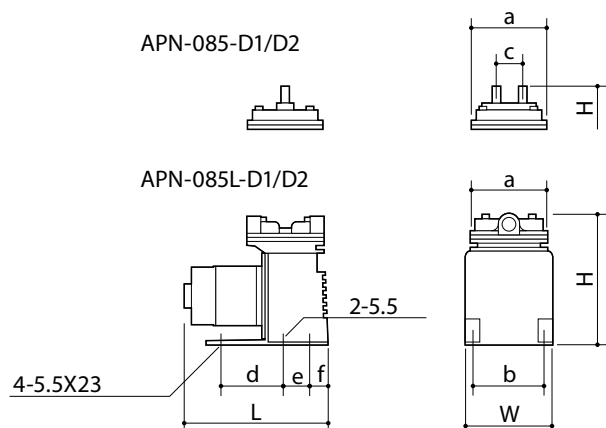

Model	W	H	L	a	b	c	d	e	f
APN-085-D1/2	80	(136)	(135)	71	66	24	57	21.5	18.5
APN-085L/H-D1/2		(121)		72	—	56.5			

APN-110

Diaphragm Air Pumps

Max. flow 14 to 28 L/min

Max. vacuum 23.99 kPa(abs.)

Max. discharge pressure 0.1 MPa



APN-110



APN-P110

Specifications

Model	Max. flow (L/min)	Max. vacuum (kPa[abs.])	Max. discharge pressure (MPa)	Power consumption (W)	Rated current (A)	Rated voltage (V)
APN-110K/L-D4	14	23.99	0.1	33.6	1.4	DC24
APN-P110L-D4	28	23.99	0.1	55.2	2.3	DC24

Connection size IN/OUT Hose barb Ø8mm, 110: Thread Rc1/4, G1/4, P110: Thread Rc1/4

Mass 110: 1.4kg, P110: 3.3kg

Allowable gas temp.0 to 40°C

Allowable ambient temp.5 to 40°C

Minimum starting temperature ...5°C

Construction and Materials

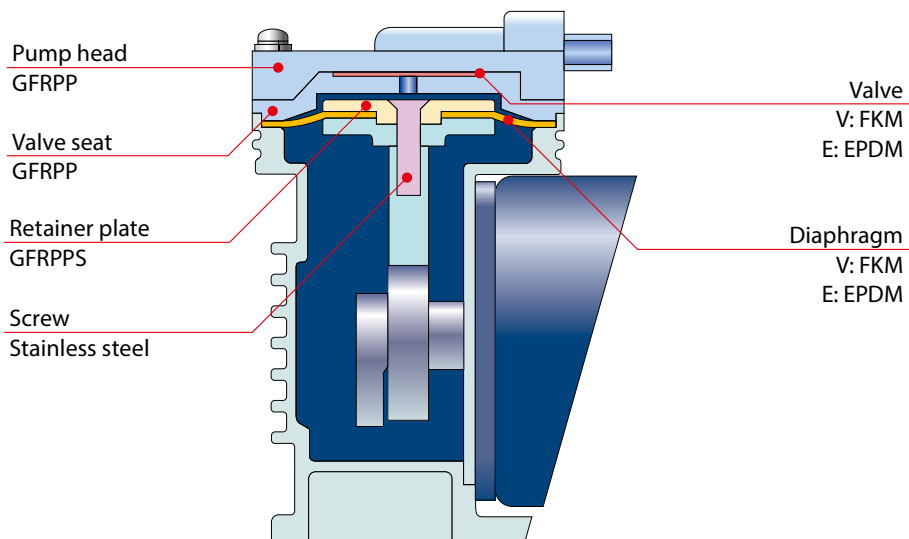

Pump Identification

APN - P 110 L V X - D4 - 02

1 2 3 4 5 6 7

1 Pump head
No symbol : Single hend
P : Dual-head

2 Pump size
110

3 Inlet/outlet
K : Parallel type
L : In-line type

4 Diaphragm/Valve materials
E : EPDM
V : FKM

5 Pump connection
No symbol: Hose barb (O.D.ø8)
X : Thread (Rc1/4)
X1: Thread (G1/4)

6 Motor
D4 : Brushless 24VDC(with Variable speed control)

7 Special version

Performance Curves

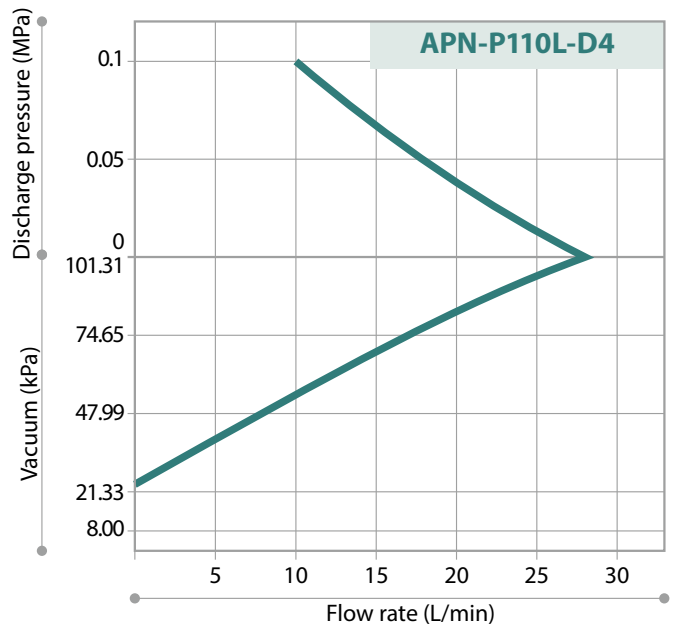
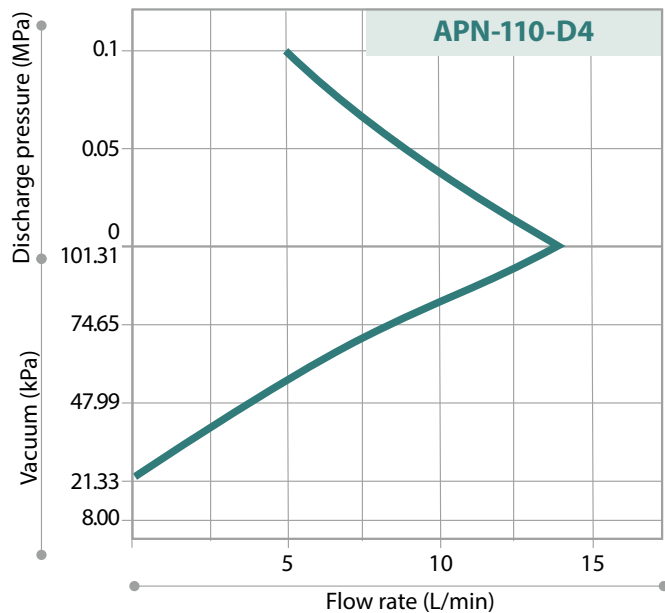

Dimensions in mm

APN-110L V/E X/X1



APN-110K V/E (X/X1)



APN-P110LX



APN-110L V/E

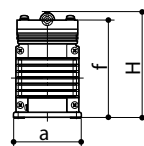
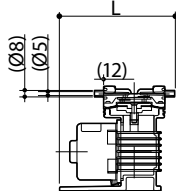

APN-P110L

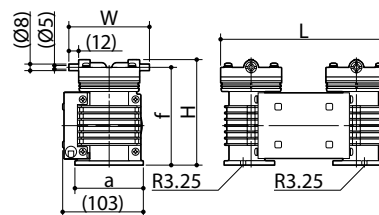

Model	W	H	L	a	f
APN-110K V/E			134		
APN-110K V/E X/X1	78	134		74	124
APN-110L V/E			146		
APN-110L V/E X/X1			134		

Model	W	H	L	a	f
APN-P110L	(102)	(134)	(129)	86	124
APN-P110LX	(78)				

APN-05/10/20-W

Gas and Liquid Transfer Pumps

Max. capacity (Gas-liquid) 0.05 to 0.26 L/min

Max. flow (Gas) 0.1 to 0.2 L/min

Max. vacuum 74.66 to 87.99 kPa(abs.)

Max. discharge pressure 0.03 MPa

Always use a suction valve to adjust an air / liquid flow.



APN-10-W
Brushed motor type



APN-10-W
Brushless motor type

Specifications

Model	Motor	Gas-liquid Max. capacity (L/min)	Gas Max. flow (L/min)	Max. vacuum (kPa[abs.])	Max. discharge pressure (MPa)	Power consumption (W) DC12/24	Rated current (A) DC12/24	Rated voltage (V)
APN-05-W		0.05	0.1	87.99	0.01	4.8/4.8	0.4/0.2	DC12/24
APN-10-W	Brushed	0.1	0.2	74.66	0.03			
	Brushless	0.18			0.03 ^{Note1}	-/7.2	-/0.3	
APN-20-W	Brushed	0.2			0.03	-/4.8	-/0.2	
	Brushless	0.26			0.03 ^{Note1}	-/7.2	-/0.3	

Connection size IN/OUT APN-05/10-W: Hose barb Ø4.5mm, APN-20-W: Hose barb Ø5mm

Mass Brushed type: 0.11kg, Brushless type: 0.2kg

Allowable gas temp. 5 to 40°C

Allowable liquid temp. 10 to 40°C

Minimum starting temperature ...5°C

Note: Max. discharge pressure of the gas-liquid transfer is 0.1MPa.

Construction and Materials

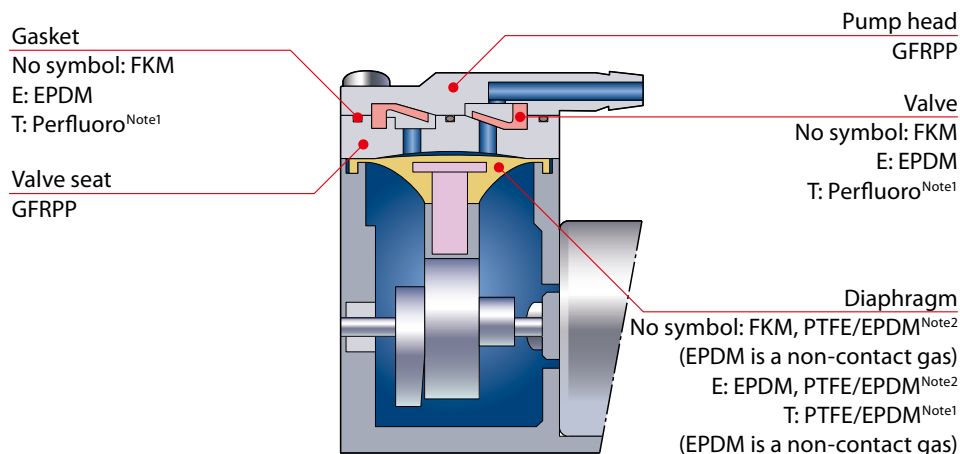

Note1: Special order on APN-10/20-W.

Note2: Diaphragm of APN-10 / 20D3-W is the PTFE / EPDM.

Pump Identification

APN - 10 G E D1 - W 02

1 2 3 4 5 6

<p>1 Pump size 05, 10, 20</p> <p>2 Bracket type No symbol : Without base G : With base</p>	<p>3 Diaphragm/Valve/Gasket materials No symbol : FKM E : EPDM^{Note1} T : PTFE/EPDM Perfluor^{Note1}</p> <p>4 Motor D1 : Brushed 12VDC^{Note2} D2 : Brushed 24VDC D3 : Brushless 24VDC^{Note1}</p>	<p>5 Type W : Gas-liquid transfer</p> <p>6 Special version</p>
--	---	--

Note1: 10-20 only
Note2: 05-10 only

Performance Curves

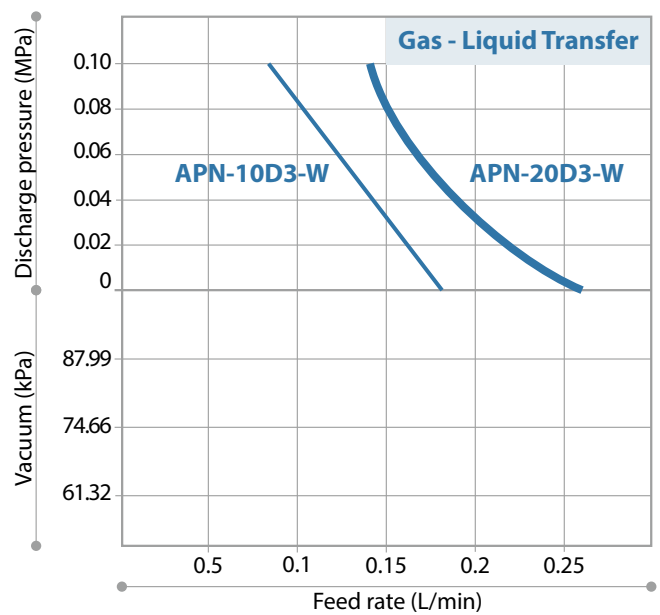
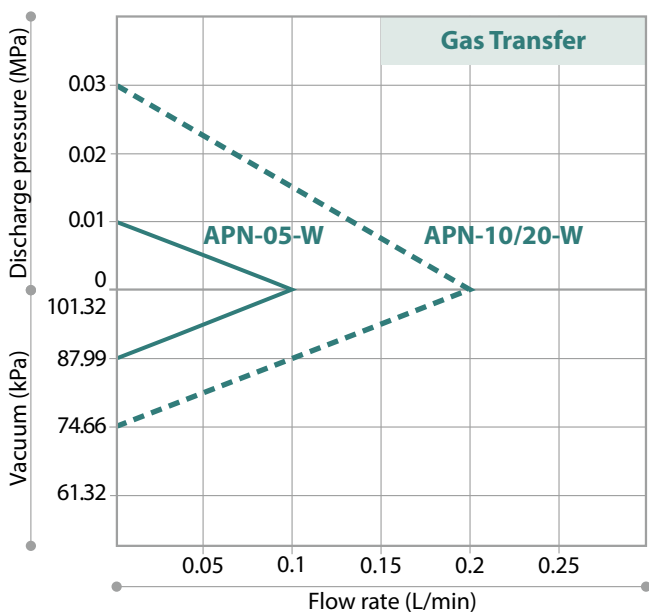

Dimensions in mm

APN-05/10-W

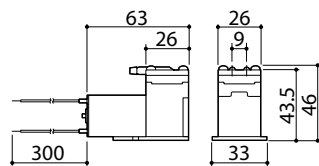

APN-20-W

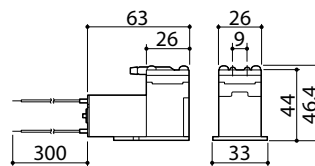

APN-10-W Brushless

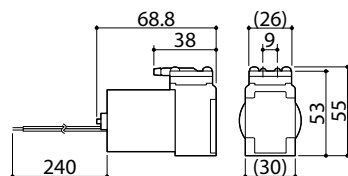

APN-20-W Brushless

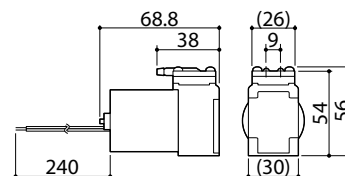

APN-30/60-W

Gas and Liquid Transfer Pumps

Max. capacity (Gas-liquid) 0.3 to 1.0 L/min

Max. flow (Gas) 1.0 to 2.4 L/min

Max. vacuum 47.99 kPa(abs.)

Max. discharge pressure 0.08 MPa

Always use a suction valve to adjust an air / liquid flow.



APN-30/60-W
Brushed motor type



APN-30/60-W
Brushless motor type



APN-P60-W
Dual head type

Specifications

Model	Motor	Gas-liquid Max. capacity (L/min)	Gas Max. flow (L/min)	Max. vacuum (kPa[abs.])	Max. discharge pressure (MPa)	Power consumption (W)	Rated current (A)	Rated voltage (V)	
APN-30-W	Brushed	0.3	1.2	47.99	0.08	11.5	0.48	DC24	
	Brushless		1.0			14.4	0.6		
APN-60-W	Brushed	0.6	1.2			0.08 ^{Note}	11.5		0.48
	Brushless		1.0				14.4		0.6
APN-P60-W		1.0	2.4			20.6	0.86		

Connection size IN/OUTHose barb Ø5.5mm

Mass30/60 Brushed type: 0.21kg, 30/60 Brushless type / P60: 0.24kg

Allowable gas temp.5 to 40°C

Allowable liquid temp.10 to 40°C

Minimum starting temperature ...5°C

Note: Max. discharge pressure of the gas-liquid transfer is 0.05MPa.

Construction and Materials

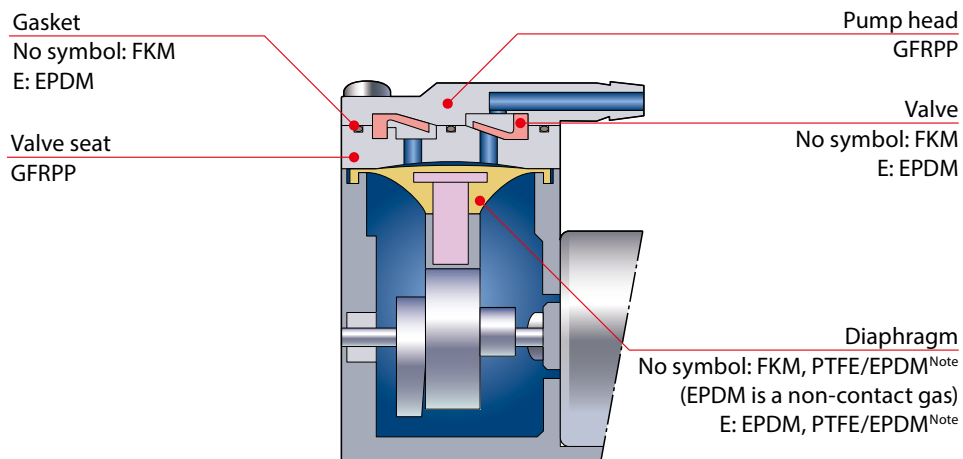

Note: Diaphragm of APN-P60-W is PTFE / EPDM.

Pump Identification

APN - 30 G E D1 - W 02

1 2 3 4 5 6

- 1 Pump size
30, 60
- 2 Bracket type
No symbol : Without base
G : With base
- 3 Diaphragm/Valve/Gasket materials
No symbol : FKM
E : EPDM
- 4 Motor
D1 : Brushed 12VDC^{Note}
D2 : Brushed 24VDC
D3 : Brushless 24VDC (without speed control)
- 5 Type
W : Gas-liquid transfer
- 6 Special version

Note: Please contact us for details about brushed 12VDC products.

APN - P 60 G E D4 - W 02

1 2 3 4 5 6 7

- 1 Pump head
P : Dual-head with parallel tubing
- 2 Pump size
60
- 3 Bracket type
No symbol : Without base
G : With base
- 4 Diaphragm/Valve/Gasket materials
No symbol : PTFE/EPDM • FKM
E : PTFE/EPDM • EPDM
- 5 Motor
D4 : Brushless 24VDC (with Variable speed control)
- 6 Type
W : Gas-liquid transfer
- 7 Special version

Performance Curves

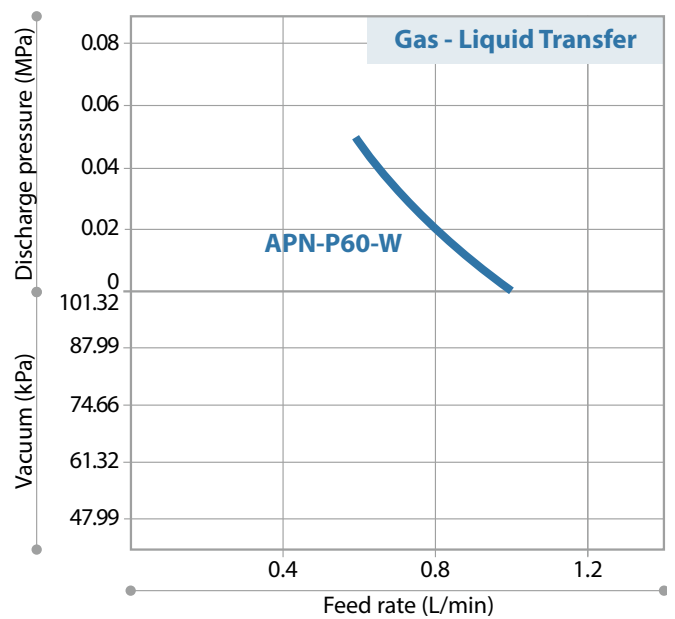
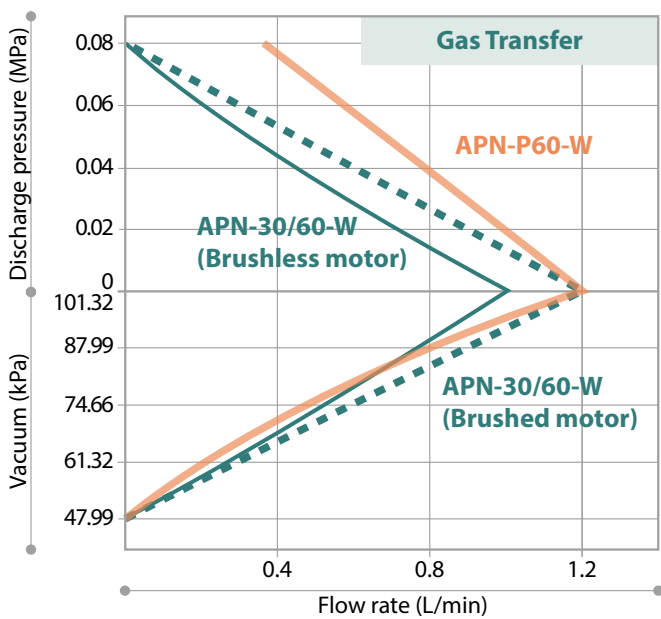

Dimensions in mm

APN-30/60-W Brushed

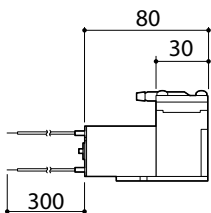

APN-30/60-W Brushless

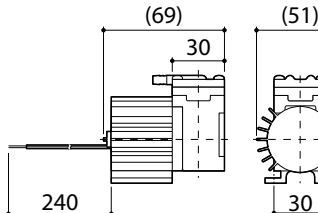

APN-P60-W without base

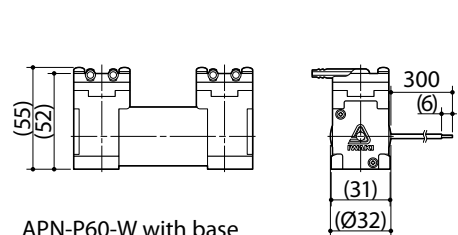

APN-P60-W with base

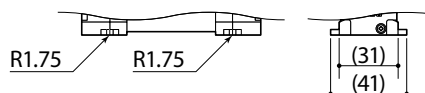

APN-085-W

Gas and Liquid Transfer Pumps

- Max. capacity (Gas-liquid) **0.5 L/min**

- Max. flow (Gas) **4.0 L/min**

- Max. vacuum **34.66 to 37.33 kPa(abs.)**

- Max. discharge pressure **0.05 MPa**

Always use a suction valve to adjust an air / liquid flow.



Specifications

Model		Gas-liquid Max. capacity (L/min)	Gas Max. flow (L/min)	Max. vacuum (kPa[abs.])	Max. discharge pressure (MPa)	Power consumption (W) DC12/24	Rated current (A) DC12/24	Rated voltage (V) DC12/24
APN-085-W	EX type	0.5	4.0	34.66	0.05	19/19	1.6/0.8	DC12/24
	VX type			37.33				

Connection size IN/OUTThread Rc1/8

Mass2.5kg

Allowable gas temp.0 to 40°C

Allowable liquid temp.5 to 40°C

Minimum starting temperature ...FKM: 10°C, EPDM: 5°C

Construction and Materials

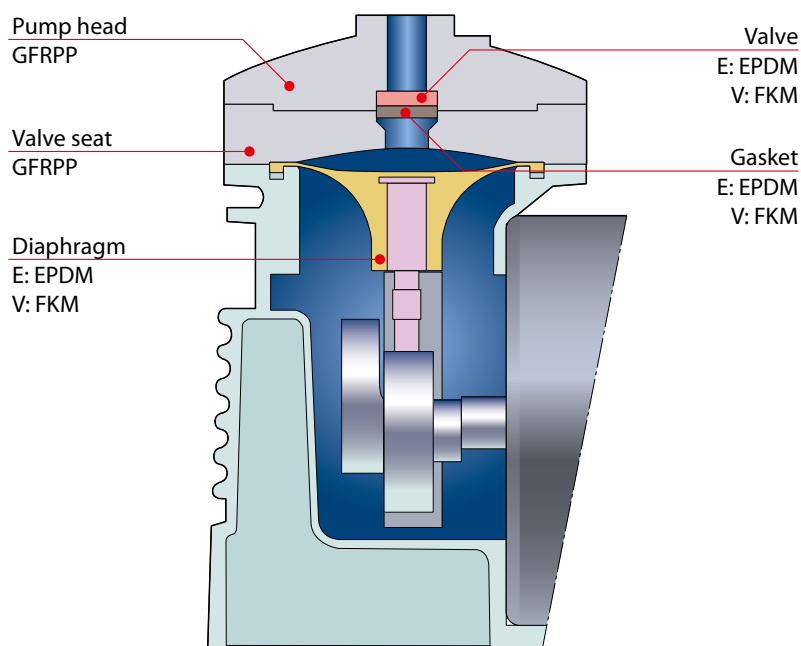

Pump Identification

APN - 085 E X - D1 - W 02

1 2 3 4 5 6

1 Pump size
085

2 Diaphragm (Valve) materials
E: EPDM
V: FKM

3 Connection size
X: Thread (Rc1/8)

4 Motor
D1: Brushed 12VDC
D2: Brushed 24VDC

5 Type
W: Gas-liquid transfer

6 Special version

Performance Curves

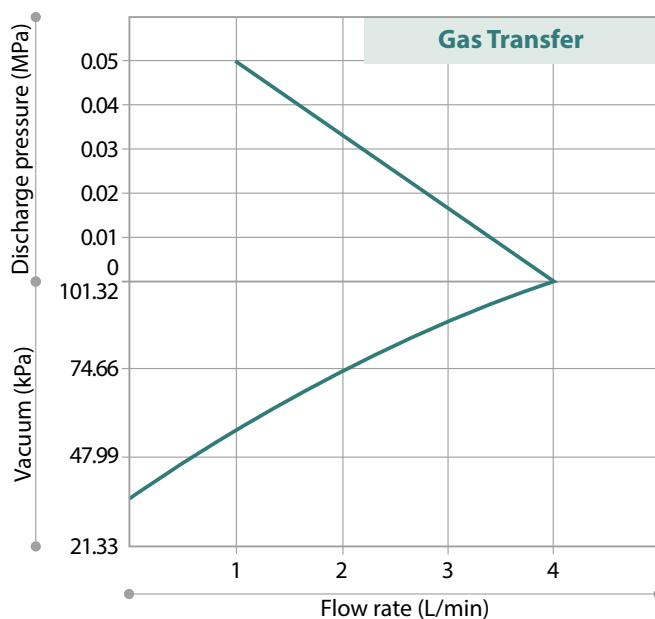

Dimensions in mm

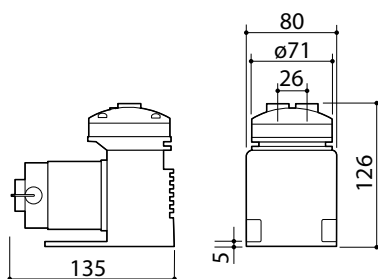

Optional Accessory

Muffler / Filter (APN series)

To be used as muffler when installed at discharge side and also as filter when installed at suction side. (Check valve incorporated filter is available as option)



This may not be usable for some pump models and pump head design. When installed, performance will be affected.

AF - 2 V - 1 C

1 2 3

1 Materials	2 Connection diameter	3 Options
V : FKM	1 : G1/8 (APN-215)	C : with check valve incorporated
E : EPDM	2 : G1/4 (APN-085)	
N : CR / NBR (gasket/O-ring, check valve)		

IWAKI CO., LTD. 6-6 Kanda-Sudacho 2-chome Chiyoda-ku Tokyo 101-8558 Japan TEL : (81)3 3254 2935 FAX : 3 3252 8892

IWAKI has global net work.
Please find your distributor location at

www.iwakupumps.jp

European Headquarter	IWAKI Europe GmbH	TEL: (49)2154 9254 0	FAX: (49)2154 9254 48	U.S.A.	IWAKI America Inc.	TEL: (1)508 429 1440	FAX: (1)508 429 1386
Germany	IWAKI Europe GmbH	TEL: (49)2154 9254 50	FAX: (49)2154 9254 55	Brazil	IWAKI Do Brasil Comercio De Bombas Hidraulicas LTDA.	TEL: (55)19 3244 5900	FAX: (55)19 3244 5900
The Netherlands (Netherlands Branch)	IWAKI Europe GmbH	TEL: (31)74 2420011	FAX: (49)2154 9254 48	China (Shanghai)	IWAKI Pumps (Shanghai) Co., Ltd.	TEL: (86)21 6272 7502	FAX: (86)21 6272 6929
Italy (Italy Branch)	IWAKI Europe GmbH	TEL: (39)0445 561219	FAX: (39)0445 569088	China (Hong Kong)	IWAKI Pumps Co., Ltd.	TEL: (852)2607 1168	FAX: (852)2607 1000
Spain (Spain Branch)	IWAKI Europe GmbH	TEL: (34)934 741 638	FAX: (34)934 741 638	China (Guangzhou)	GFTZ IWAKI Engineering & Trading Co., Ltd.	TEL: (86)20 84350603	FAX: (86)20 84359181
Poland (East Europe Branch)	IWAKI Europe GmbH	TEL: (48)12 347 0755	FAX: (48)12 347 0900	Singapore	IWAKI Singapore Pte Ltd.	TEL: (65)6316 2028	FAX: (65)6316 3221
Denmark	IWAKI Nordic A/S	TEL: (45)48 242345		Indonesia (Indonesia Office)	IWAKI Singapore Pte Ltd.	TEL: (62)21 6906606	FAX: (62) 21 6906612
Finland	IWAKI Suomi Oy	TEL: (358)10 201 0490		Malaysia	IWAKIm SDN. BHD.	TEL: (60)3 7803 8807	FAX: (60)3 7803 4800
Norway	IWAKI Norge AS	TEL: (47)23 38 49 00		Korea	IWAKI Korea Co.,Ltd.	TEL: (82)2 6238 4800	FAX: (82)2 6238 4801
Sweden	IWAKI Sverige AB	TEL: (46)8 511 72900		Taiwan	IWAKI Pumps Taiwan Co., Ltd.	TEL: (886)2 8227 6900	FAX: (886)2 8227 6818
Belgium	IWAKI Belgium N.V.	TEL: (32)13 670200	FAX: (32)13 672030	Thailand	IWAKI (Thailand) Co.,Ltd.	TEL: (66)2 322 2471	FAX: (66)2 322 2477
France	IWAKI France S.A.	TEL: (33)1 69 63 33 70	FAX: (33)1 64 49 92 73	Australia	IWAKI Pumps Australia Pty Ltd.	TEL: (61)2 9899 2411	FAX: (61)2 9899 2421

() Country codes

Caution for safety use:
Before use of pump, read instruction manual carefully to use the product correctly. Actual pumps may differ from the photos. Specifications and dimensions are subject to change without prior notice. For further details please contact us.

Legal attention related to export.
Our products and/or parts of products fall in the category of goods contained in control list of international regime for export control. Please be reminded that export license could be required when products are exported due to export control regulations of countries. The posting and copying from this catalogue without permission is not accepted firmly.